



A shipwreck research project funded by the European Union Culture 2000 Programme

contents

Project publications:

- Newsletter 2002:I
Theme: Introduction
December 2002
- Newsletter 2003:I
Theme: Vrouw Maria
May 2003
- Newsletter 2003:II
Theme: The Darss Cog
June 2003
- Newsletter 2003:III
Theme: The Eric Nordevall
October 2003
- Newsletter 2003:IV
Theme: The Burgzand Noord 10
December 2003
- Newsletter 2004:I
Theme: The Visualization Theme
January 2004
- Newsletter 2004:II
Theme: The Monitoring Theme
March 2004
- Newsletter 2004:III
Theme: The Safeguarding Theme
May 2004
- Final Report

Final Report

Alvik, Tikkanen: Introduction 2

Palma: Final Report for the Monitoring theme of the MoSS Project 8

Gregory: Monitoring Wooden Shipwrecks: Monitoring The Burgzand Noord 10 and Darss Cog using the EauxSys data logger 38

Leino, Jöns, Wessman, Cederlund: Visualizing Underwater Cultural Heritage in the MoSS-project 49

Oosting: The Four Wrecks of the MoSS Project, Their Time and Cultural Settings 52

Kresse: The last results of the photogrammetric mapping of Darss Cog 57

Wessman: The reconstruction of Vrouw Maria: Building a ship from upwards down 61

Manders, Lüth: Safeguarding 63

Manders: Combining "Monitoring, Safeguarding and Visualizing" to Protect our Maritime Heritage 74

Cederlund: Project evaluation 76



Education and Culture

Culture 2000

Introduction

What is MoSS? MoSS (Monitoring, Safeguarding and Visualizing North-European Shipwreck Sites) was an international research project. The project started at the beginning of July 2001 and ended at the 30th of June 2004. The main goal of the project was to make people aware of the importance of our common underwater cultural heritage. Another aim was to develop good practices in safeguarding, monitoring and visualizing underwater cultural heritage. Good practices help the authorities and professionals in marine archaeology to protect, research and take care of the underwater cultural heritage. These practices are meant to be practical tools for the management and protection of underwater archaeological and historical sites, methods for measuring the environmental factors, for example, or techniques for surveying and researching the sites, and ways of managing them. The UNESCO Convention for the Protection of the Underwater Cultural Heritage and the ICOMOS Charter on the Protection and Management of Underwater Cultural Heritage are important guidelines when creating these practices.

Because maritime archaeology is an international discipline it was natural to seek for international co-operation. The Maritime Museum of Finland had good experiences of projects connected to the European Union so it was natural to look for a suitable research programme within the Union. The idea was also to create a project that would interest other marine archaeologists, research institutions and museums in Europe. In the year 2001 the Culture 2000 Programme supported initiatives in four areas, two of which were linked to history: the common European cultural heritage and the mutual

Editorial

The Final Report of the MoSS Project is to be read in connection with the contents of the eight newsletters produced during the three years span of the project. The Monitoring Theme representatives give two covering reports on this theme on page 8 and 38. The themes and aspects of Safeguarding, Visualization, documentation etc. are represented with several discussing papers. They are all referring to earlier representations of these subjects in the newsletters of the project.

knowledge of history and culture of the peoples of Europe. One specific topic for the projects implementing perennial cultural co-operation was the sub-aquatic archaeology of relics of European significance. The MoSS Project was accepted as a part of the programme and for that reason the funding of the project came not only from the participating countries but also from the European Community Culture 2000 Programme.

The project is organised by six European countries: Finland (as the

Carl Olof Cederlund Editor

In the paper on Monitoring, Safeguarding, and Visualization on page 74 Martijn Manders gives a conclusion of the main ideas of the combination of the three themes of the project - and the development of the same in the future. The report texts are framed in by the Introduction, depicting how the project was imagined, designed and realized - and the Project evaluation on page 76 in which the partners present their views and experiences on central, organizational and thematic issues of the MoSS Project.

coordinator), Sweden, Germany, Denmark, the Netherlands, and Great Britain. Denmark is participating in the project as a consulting partner. The project has three main themes: monitoring, safeguarding and visualising. It also opens an underwater window to four important shipwreck sites: the Vrouw Maria in Finland, the Eric Nordevall in Sweden, the Darss Cog in Germany and the Burgzand Noord 10 in the Netherlands. The Darss Cog is dated in the medieval times, to the end of the 13th century, the Burgzand Noord is a 17th century



Audience at the second project seminar at Forsvik on the theme of visualization.

merchant ship, the *Vrouw Maria* is a Dutch snow ship that sunk in 1771, and the *Eric Nordevall* is a steam paddle ship from the 19th century. The wrecks of *Vrouw Maria* and *Eric Nordevall* are almost intact as to their hull. The fieldwork and survey at these sites had already started before the MoSS Project, so there was previous information about them. The fieldwork at the sites was very active throughout the MoSS Project.

All the chosen research sites differ from one another in their ship types, environmental factors and origin. Comparing the results from the studies of these different sites is a challenging task. Our aim is to make the good practices applicable to all kinds of sites in different environments. The local management of cultural heritage and the legislation concerning underwater cultural heritage have to be taken into account, too. The project's aim is not to change legislation but to give solutions for the better managing, protecting and presenting of the underwater cultural heritage.

Origins of the idea of MoSS

In Finland the starting point of the MoSS Project was the discovery of the wreck of *Vrouw Maria* in 1999. This remarkable discovery of the almost intact wreck, which is lying on its keel on the sea bottom, got huge attention in the Finnish media. Also foreign newspapers noted the find, especially in the Netherlands where the ship originated. The wreck was seen as a treasure ship because of her valuable cargo consisting of precious artworks bought in Dutch auctions by the Russian empress Catherine the Great. The artworks were not in the list of the recovered cargo in 1771, which means they might still be in the cargo hold. That is why the shipwreck interests also art historians, art collectors and enthusiastic divers, too.

In the summer of 1999 also the then Minister of Culture Ms. Suvi Linden got interested in the find and arranged extra funding to the Maritime Museum of Finland for the research of the wreck. At that time it was the Maritime Museum of Finland that was responsible of the management and research of underwater cultural heritage in Finland. Those days at the museum there was only one maritime archaeologist, who was appointed only for a fixed term, and in addition, the funding for the survey of the sites was minimal. In other words, the resources for researching the wreck of *Vrouw Maria* were totally inadequate. With the extra funding from the Ministry of Education and Culture the museum was able to employ two researchers for the research work and make plans for the next couple of years.

It was anyway obvious that more funding and qualified researchers were needed and that the period of the first research phase had to be long enough. One of the reasons for applying funding for the MoSS Project from the European Commission was also that the wreck of *Vrouw Maria* was considered as a significant find and international co-operation with professionals in Europe, the USA, Canada, and Australia was considered necessary. By the help of this new marine archaeological project it was possible to develop Finnish maritime archaeology, to employ and educate local maritime archaeology students and professionals, and create an international network of professionals in maritime archaeology. One of the main points was to have the knowledge gained from the MoSS Project applicable to other sites, too. All the sites have different characteristics but there are certain features that follow a pattern. All the wrecks ought to be considered valuable even if they are not full of artefacts or as intact as the wreck of *Vrouw Maria*. It was of course easier

to get funding for a well-known and exciting site than for a site with high scientific value but without greater visual or other values.

Creating the project

The preparation of the application was made in Finland by the staff of the Maritime Museum of Finland, which was the co-ordinator of the project. The preparation of the application was a very multi-phased process. The general idea of the project was established when we found suitable partners. We started the search for partners in early spring the year 2001 by sending a letter to several institutions and museums in Europe. The letter presented a draft of the contents and the different scientific themes of the project. The idea was also presented in a maritime archaeological conference in Germany, Rostock in March 2001. Because of the tight time schedule e-mail was a very useful tool of communication when developing the more detailed application. During the application process there was one meeting with the partners in Helsinki in April 2001. There was some last-minute stress because one of the partners was changed at the very end of the process. The project was not presented in the European Commission office in Brussels because of the tight time schedule but the co-ordinator was in contact with the Finnish Culture 2000 Office that assisted in the application process.

All the partners participated in the preparation work and in the more detailed planning of the project. One of the most challenging tasks in making the application was to plan the fieldwork for the chosen shipwreck sites for the period of several years. Maritime archaeological fieldwork is always very expensive and especially so when high technology is used and new methods are tested. Maritime archaeological fieldwork requires also

a lot of qualified staff. Researching the sites was one of the basic tasks of the project, and approximately 36 % of the total funding was budgeted in it.

The Culture 2000 Programme in itself is quite demanding: the projects within the programme must contain certain amount of actions like seminars, meetings, publications, Internet sites, posters and brochures. Raising awareness of the common European cultural heritage and distributing information to the general public is essential. The co-ordinator's duty was to make the application and actions planned suitable for the Culture 2000 Programme. Our local Culture 2000 Office gave us a lot of help and advice especially with the practical matters in filling in the application. We also got a lot of advice and good information from the then ongoing Culture 2000 Projects in Finland. The acceptance of our application shows that you can succeed even if you do not have previous experience in this kind of a project. None of us, the partners of the project, that is, had any experience on this kind of a project before MoSS. To have your application accepted by the European Commission, it must be filled in very carefully and the demands of the programme have to be fulfilled. The contents must be well planned, reasonable, and appropriate for the project, and the plans have to be realistic as to the time limits and the budget of the project. The results must benefit European community and people and preferably have a long-term influence. That is why the project should be interactive and include the possibility of the general public's participating in it.

It is very important to arrange open seminars, exhibitions, to create an Internet site and to give lectures. Planning the budget had to be very detailed. The actions have to run in a logical way throughout the project. The

application has to have information about the partners' role and their actions during the project. You must describe the methods that make it possible to achieve the planned results and you must explain how the information will be distributed. Planning and describing all this was very time consuming, but all the work was worth it. The MoSS Project was the first project on underwater cultural heritage that was accepted in the Culture 2000 Programme. It took the co-ordinator approximately four months full time work to prepare the application, and each of the other three members of the Finnish team used approx. one and a half months in this. The other partners of the project used 3-6 weeks for the preparation work depending of their role in the project. The application of the MoSS Project was taken by the Finnish Culture 2000 Office on the 15th of May 2001. The official announcement of the approval of the application came from the European Commission in December 2001. The agreement between the Commission and the beneficiary (The Maritime Museum of Finland, from the 1st of January 2004 on, the Section for Maritime Archaeology) was signed on the 18th of December 2001. The MoSS Project was the first Culture 2000 Project concerning underwater cultural heritage and it was a pilot project when it comes to its contents, too. The grant given by the Culture 2000 Programme was 690 682 EUR (approximately 60 % of the total funding) and the total budget of the project was 1 157 482 EUR. The rest of the money, 466 800 EUR, came from the participating countries except Denmark, which was merely a consulting member in the project.

Managing and organising the project

The participating organisations and institutions are The National Board of Antiquities / The Section for Maritime

Archaeology (FIN), the Södertörns högskola (University College) (SE), The Mecklenburg – Vorpommern State Museum (DE), the National Museum of Denmark (DK), ROB / Netherlands Institute of Maritime Archaeology (NL), and Mary Rose Archaeological Services Ltd (GB). In Finland, the MoSS Team consists of one curator as a co-ordinator of the project, a project secretary, two researchers, one conservator and one part time research assistant. The two researchers work in the Vrouw Maria research team and the MoSS Project full time while the rest of the team, including the co-ordinator, works in the project only part time. Based on the experience we now have, it would be better to employ full time workers and separate them from their daily working routines at the institution or museum in question. The bureaucracy, the planning and fulfilling of the tasks mentioned in the application require fulltime work and one cannot perform a number of big tasks all at once.

Most of the participants in the other countries are researchers, professors or curators who work in the field of maritime archaeology. There are different kinds of operators in the project: one private company (the Mary Rose Archaeological Services Ltd), one university college (Södertörns högskola), one institution funded by the government of the Netherlands (ROB/NISA), and three national museums, which are responsible for the management of the underwater cultural heritage on their area. The local representatives of the European Commission assisted these parties. The differences in the characters of the operators had both a positive and a negative side. It would be easier to fulfil the required tasks in practice if the all other parties possessed legal status concerning the cultural heritage and there were established traditions in taking care of the heritage. The positive

side is the possibility of exchanging ideas and learning new ways of working.

The management and reporting of the economy matters was taken care by the project co-ordinator and the secretary in the co-ordinating country. The co-ordinator has the roles of both an administrator and a researcher. The administration of EU projects is very time consuming especially when the partners are located in different parts of Europe and it is not possible to arrange meetings very often. In the administration, also the laws and rules of all the coordinating countries have to be obeyed. The partners have to report their accounts and actions in their own countries too to make sure that the national rules are obeyed. This causes extra work. It is demanding to get all the reports in different countries similar, clear and efficient. The project secretary takes care of economy matters and she also has a very important role in the communication and annual reporting to the European Commission. A qualified and skilled secretary is very important for a big project like MoSS. The co-operation with the Culture 2000 co-ordinators is very rewarding. They give advice in managing the project and on the other hand they appreciate the information they receive because it helps them to develop other European cultural programmes.

Decision making in the project

The decisions are made democratically in joint meetings, which are arranged several times a year. Each of the partners has one vote and it is possible to take a vote if necessary. E-mail is also a very important tool in keeping contact and negotiating with each other. All reporting and the basic rules of the project are based on the rules of the Culture 2000 Programme and the laws and orders of the European Community. Every country

has its own legislation concerning the cultural heritage and these laws are strictly obeyed in all actions taken within the project.

In the project there is also a project evaluation board (PEB), which meets as often as the project has common meetings. There is one member from each participating country in the board. The internal evaluator of the project, professor Carl Olof Cederlund, is the chairman of the board. The task of the board is to evaluate the project's work and give suggestions concerning the development of the project. The evaluation board has been found extremely important when it comes to the developing of the good practises and when opinions about the decisions and actions done in the project change. Self criticism is good for the internal development but it is equally important to become aware of the success and good results in the project as well.

The external evaluator assesses the project by studying the results: scientific results, publications, seminars, distributed information etc. If necessary, he may participate in the meetings and give advice to the participants. The external evaluator is not participating in the practical work of the project but gives an outside view. In this kind of a pilot project the evaluation, both internal and external, is very important for the future development of the project and the possible co-operation following it. We hope that projects similar to ours could benefit from our experience.

Development in the project

MoSS was a three-year project. The tasks were separated in phases and precise time schedules were made at the beginning. The time schedule and the roles and tasks of the participants in the implementing of the project are all mentioned in the agreement between the beneficiary and the

European Commission. It is possible to make changes in the agreement, but not very big ones, and everything must be done within the limitations of the budget (both national and the EU). All changes must be reported to the Commission and in some cases you have to ask your EU contact person for permission to do alterations. The limitations concerning possible changes in the structure of the budget were in some cases seen as complicated since there were certain expenses that were very difficult to plan beforehand. One of these costs comes from translations; in this kind of a multi-lingual project translations are needed and the money we budgeted for them was not adequate.

The tasks are roughly divided into the scientific research of the different themes, the analysis of the results, the creating of the good practises, the distributing of information in different ways, and the results and conclusions. The number of our newsletter issues was originally planned so that the project itself, the different sites, themes and finally the results all would have their own issues. But since the size of an issue is very limited (16–22 pages), the results of the project had to be presented in a scientific publication instead to give a wider view of the project and its achievements.

Some of the tasks were performed within the planned time schedule. For example the scientific research at the sites went very well. The fact that the project was officially accepted to the Culture 2000 Programme half a year after the formally agreed beginning of the project influenced the whole project. The delay affected for example the analyses of the samples put on the sites. The newsletters, posters, folders and the Internet site were more time consuming tasks than estimated, and the first newsletter was published much later than planned. During the

first year of the project most of the time was spent in creating the administration and the working methods, and also in getting to know each other. Most of the partners had not co-operated in this way before, and it took time before the working methods adapted to each other. An important matter was to learn open communication between the partners. At the beginning there were difficulties in finding the best ways to communicate but it improved in the course of the project. Openness between the partners and courage to express opinions is important in projects that include many tasks in a very limited time. The communication manners that developed within the MoSS Project made a good basis for future co-operation.

The scientific research done within the project continued throughout the same. The results are published in scientific articles and publications during and after the project. The long-term effects may be seen more clearly later. Most of the publications created within MoSS were published in the second and the third year of the project. Because of the delays the work accumulated, which was rather difficult. All the partners have other projects and tasks too, so their time for this project was limited. That is why we recommend that at least some of the partners have full time employees for the project. The newsletters were found as a very good way of presenting the tasks and results of the project but the number of them was too big. The posters and folders were published later than planned, but the feedback from colleagues and public was good, and they achieved their purpose.

The third year of the project is the most important because the results are analysed and interpreted. The results and achievements must be published and distributed to the colleagues and the general public. The time schedule is very tight because of the earlier

delays but also because there is now such a huge amount of experience and knowledge received from the research work at the sites and in the laboratories of the Mary Rose Archaeological Service Ltd.

The scientific research in MoSS

The scientific research of underwater cultural heritage is not very well developed in many European countries even though it is generally known that there are very well preserved ship wrecks and other remains of the human past in the northern parts of the Baltic Sea. In the brackish waters of the northern Baltic there is no *Teredo navalis* or other wood-eating organisms. In the southern parts of the Baltic there are already serious problems, like *Teredo navalis*, and wooden remains are under constant threat.

There are also other factors, like heavy traffic on the sea routes, which make these sites vulnerable, and it is very important to develop scientific research and the methods of protecting the sites now when there is still something left for the future generations. Ancient monuments are considered to be non-renewable, so damaging them changes sites permanently. According to the ICOMOS charter, the underwater cultural heritage is by its very character an international resource. The responsibility of preserving the common cultural heritage is collective and it is very important to find good methods for this task. Planning and testing these methods requires qualified archaeologists and other professionals, for example experts in marine biology and environmental sciences.

The ICOMOS charter also points out that archaeology is concerned with environmental conservation. All impacts on the environment, natural and for example human, affect to archaeological remains. That is why safeguarding and monitoring go hand in hand in the research: To find the

ways to safeguard shipwrecks we need to monitor them. Visualising is one way of monitoring the sites but also a method of letting people see the sites without diving to them. We can use different kinds of visualising methods for scientific purposes, and via visualising we are also able to raise the general public's awareness of these very unique remains of human past and great innovations.

In the MoSS Project the scientific research was done at three sites: the Vrouw Maria, the Darss Cog and the Burgzand Noord 10. The research work for MoSS purposes started by the help of national funding in the summer of 2001, that is, before we received the official acceptance of our EU application. The three countries were Finland (Vrouw Maria), Germany (Darss Cog) and the Netherlands (Burgzand Noord 10). The research work done at the Swedish site, Eric Nordevall, is based on former research work and new interpretations of it.

These three sites are monitored in different ways. At the shipwrecks, different measurements were taken and data was collected by analysing samples that were placed near the shipwrecks. In addition, the conditions at the sites were measured by data-loggers. A data-logger measures currents, salinity, oxygen, redox-potential, pH, temperature, conductivity, and turbidity at a site. The results are analysed and interpreted by the English partner, the Mary Rose Archaeological Services Ltd.

The plans for safeguarding the sites are based on the results of the monitoring work and all other information collected from the sites. The national legislation and different traditions and practices concerning the research work are taken into account so that actions done within MoSS are not in contradiction with them.

When it comes to the visualising, the aim is to use not just the traditional methods like photographing, filming and drawing, but also new techniques such as fresh 3 D computer drawing systems, new underwater techniques (ROV, goniometre, Aquametre D100, etc.), documents, animations and artistic images and replicas. In Sweden an association called Forsvik's Shipyard Association is building a 1:1 copy of the Eric Nordevall. The replica will be a sailing copy of the original and it will be used in the waters where Erik Nordewall used to steam. It is very fascinating to see how people used these paddle steamers in the lake area of Sweden and what they originally looked like. It makes history more alive to the general public too. In Finland a three dimensional reconstruction is made by the help of a computer programme called Rhinoceros. The reconstruction is based on the measurements taken from the wreck of the Vrouw Maria. Also a diorama model of the wreck shows Vrouw Maria in its present location. These are important tools both to researchers and to the people who visit museums and exhibitions.

Distributing information

The Culture 2000 Programme provides us with a certain setting for the distribution of information. This has to be considered already when planning the project. The main point is that the information has to be available to the general public in as many languages as possible and it has to reach a great number of different people.

In the MoSS Project we found the idea of distributing information widely very important. At the beginning of the project we planned to do 10 newsletters, one scientific publication, one common publication especially for children and young people, to maintain an own Internet site and also publish a series of posters and a brochure of

the project. Now, at the end of the project we must confess we were a little too optimistic: the number of the newsletters had to be reduced and some of the issues were put together because of the huge amount of time each of them took. Producing a publication is always a big task, the planning and writing of the texts and choosing the pictures is only one phase. Doing the editing, layout, printing and distributing the issues take always months, which proved to be the most difficult part for us. On the other hand, the newsletters are very well liked among the professionals in maritime archaeology and we have had very positive feedback about them. All the publications are distributed free of charge as was stated in the agreement with the European Commission.

The Internet site has proved to be a very efficient channel when distributing information. In the Internet you can find basic information of the project, and the members and staff, the sites, themes and events are presented. There is only limited number of copies of our publications and that is why all the newsletters are also available to the public via the Internet. The files are in PDF format and they are printable. The National Board of Antiquities in Finland maintains the Internet site. The site will exist even when the project is over but it will not be updated.

A report of the project has been sent to the European Commission every year (First and Second Interim Report of the MoSS Project). The reports present the actions done within the project, the management of it and the accounts. The last report of the project is to be sent to the European Commission by the end of August 2004. All the documents concerning the project will be stored at least for five years and they are available to all the members of the project.

Conclusions

The achievements of the project can be seen on many different levels. The progress and achievements reached during the project affect maritime archaeology both in the international and the local field. Creating good, common practices for the management, protection and presentation of European underwater cultural heritage was very useful. For example in Finland, the MoSS Management plan for Shipwreck Sites will be taken into general use, and the methods of monitoring and visualising will be applied to other Finnish sites too. The data loggers and analyses of the samples gave scientific proof of the conditions at the chosen sites. This information is very valuable when planning the future safeguarding and monitoring of the sites. The knowledge is going to be used for other sites as well.

Raising awareness of the underwater cultural heritage succeeded. For example the Darss Cog is now one of the best-known shipwreck sites in Germany. The MoSS Project published scientific newsletters and a publication for children and young people. The participants of the project gave lectures and co-operated with the media in their home countries. This way we managed to raise common awareness of the underwater cultural heritage and its protection.

For the participants, one of the most important achievements of the project was the co-operation at the local and the international level. The MoSS Project was a pilot project with its pros and cons, and offers a very good basis for future co-operation in Europe.

Final Report for the Monitoring theme of the MoSS Project

Table of Contents for the Monitoring Theme Report

Chapter 1: General Introduction of the three sites	9
Chapter 2: Monitoring, methods and materials	10
2.1 Monitoring of the environment – use of data loggers	10
2.2 Monitoring and evaluation of wood degradation	10
2.3 Analyses of samples placed in aerobic environment	10
2.4 Analyses of samples placed in anaerobic environment	13
Chapter 3: Results	13
3.1 Vrouw Maria: samples placed in aerobic environment	13
3.2 Vrouw Maria: samples placed in anaerobic environment	16
3.3 Darsser Kogge: samples placed in aerobic environment	16
3.4 Darsser Kogge: samples placed in anaerobic environment	21
3.5 Burgzand Noord 10: samples placed in aerobic environment	23
3.6 Burgzand Noord 10: samples placed in anaerobic environment	27
Chapter 4: Conclusions	27
4.1 Vrouw Maria	27
4.2 Darsser Kogge	28
4.3 Burgzand Noord 10	28
References	28
Appendix 1: Shirley textile by Paul Wyeth ¹	29
Appendix 2: Nuclear Magnetic Resonance	32
Appendix 3: The Physical and Chemical Measurements at the Vrouw Maria Wreck Site.	32
By Riikka Hietala, Tero Purokoski, Hannu Vuori, Tuomo Roine, Juhani Rapo, and Juha Flinkman ²	
Appendix 4: Drilling resistance measurements - a fast method for the examination of	37
waterlogged archaeological wood by Prof. Dr. C. von Laar ³	

¹ Textile Conservation Centre, Winchester Campus, University of Southampton

² The Finnish Institute of Marine Research

³ University of Technology, Business and Design, Department of Civil Engineering, Wismar

Chapter 1: General Introduction of the three sites

In July 2001 the MoSS project started as a partnership between Finland (project leader), The Netherlands, Germany, Sweden and the UK, with the aim of developing a methodology and monitoring protocols to form a standard for the management of European historical wreck sites. The aim was to investigate the sites from three aspects: monitoring the environment and the degrading conditions at the sites; safeguarding the historical sites with the deployment of new systems for protection *in situ*, and visualizing the same sites to achieve a better understanding of the habitat and degrading conditions as well as the production of images representing the wreck site. The aim of the research is to assess how wreck site formation, preservation and degradation are influenced by environmental variables and how the latter are fundamental for the survival of biological aggressors. Once the impact of environmental characteristics is known, the next step is to implement a management, with a strategy for *in situ* protection of the site.

For this project, three archaeological shipwrecks in different environmental conditions have been chosen.

These are listed on Table 1.1 along with the characteristics describing the sites at the inception of the project¹.

It is important to investigate the environmental parameters of a shipwreck site, as conditions will directly influence the state of preservation of archaeological materials. Parameters may vary widely within an individual site, giving rise to different degrees of deterioration

<i>Vrouw Maria</i>	<i>Darsser Kogge</i>	<i>Burgazand Noord 10</i>
- Location: S-W Finland	- Location: North Germany	- Location: Wadden Sea in The Netherlands
- Date: XVIII Century	- Date: XIII Century	- Date: XVII Century
- Depth: 40 meters	- Depth: 6 meters	- Depth: 10 meters
- Very low level of sedimentation	- High level of sedimentation	- Very high level of sedimentation
- Currents	- Strong currents	- Strong currents
- Water movements	- Water movements	- Tidal movements
- Almost completely exposed	- 5% of the wreck exposed	50% of the wreck exposed
- Mainly aerobic conditions	- Mainly anaerobic conditions	- Mainly aerobic conditions
- Inside the wreck presence of little layer of sediment	- Inside the wreck presence of thick layer of sediment underneath which good preservation conditions.	- Inside the wreck presence of thick layer of sediment
- No freezing process	- No freezing process	- Unlikely freezing process nowadays but probably happened in earlier days
- Low temperature	- Variable temperature	- Variable temperature
- Low presence of bacterial/fungi	- Possible presence of bacteria and fungi to be investigated	- High presence of bacteria and fungi
- Unknown presence of wood borers	- <i>Teredo Navalis</i> (found in the exposed parts of the wreck)	- <i>Teredo Navalis</i> (found in the exposed parts of the wreck)
- Fouling activities	- Fouling activities	- Heavy fouling activities
- No polluted area	- Possible pollution	- No polluted area
- Quite stable site	- Stable site	- Very unstable site
- Human activity	- Human activity (including diving, fishing)	- Human activity (fishery, diving, ship movements)

Table 1.1. Sites characteristics at project start.

above and below the sediment/water interface. The underwater environment deteriorates wood, causing alterations to its properties. Changes occur at a cellular level from hydrolysis, bacterial and fungal attack, and on a macroscopic level from wood-

borers. This attack not only causes degradation and weight loss, but also physical damage to the archaeological material and loss of mechanical strength.

An important aspect of the MoSS research was to assess the different conditions of exposure, or burial, at each site.

¹ From minutes of MoSS Meeting, Portsmouth March 2002.

Chapter 2: Monitoring methods and materials

2.1 Monitoring of the environment (use of data loggers)

To measure factors such as salinity, pH, dissolved oxygen, temperature, turbidity and sediment flow, data loggers have been deployed at each site and data retrieved at regular intervals.

The programme deployed two loggers on the Darsser cog and Burgzand Noord 10 sites (WaterWatch System 2681 – SubSea Logger from EauxSys (UK) Ltd). The systems deployed on the Vrouw Maria site were the SBE16 plus SEACAT provided by Seabirds.

These aspects are described in more detail in Appendix 3 and Appendix 4.

2.2 Monitoring and evaluation of wood degradation

It is well known that exposed wood is vulnerable to marine woodborers, fungi and aerobic bacteria. To evalu-



Figure 2.1. Row of samples.



Figure 2.2. Samples attached to the framework.

ate the rate and extent of degradation, samples have been placed at each site for subsequent collection and evaluation at regular intervals.

The same methodologies have been applied at each site for the investigation of woodborer attack, wood degradation, weight loss, moisture content, and fungal and bacterial attack. Two systems have been devised to investigate attack, taking place in the aerobic and anaerobic environments respectively.

Sample preparation for the aerobic environment

Three types of wood were chosen for the investigation of the aerobic environment: fresh pine (*Pinus sylvestris*), fresh oak (*Quercus* sp), and archaeological oak (*Quercus* sp.). Samples were cut into 20x7x2.5 blocks, weighed and deployed in triplicates. To assess the validity of protection in situ, the synthetic geotextile Terram, was also employed in four different grades of mesh (500, 1000, 2000, 4000). Rectangular “bags” were cut and sewn around wood samples to assess their effectiveness in preventing or reducing

degradation. These “bags” were then attached to each other by means of cable ties, to form rows of seven or eight samples (Fig.2.1), which were attached to steel frames (Fig.2.2), and placed on site above the sediment surface. Five complete frames were deployed at each site, each one relating to a specific proposed period of exposure. (3, 12, 24, 36, 48 months)

2.3 Analyses of samples placed in aerobic environment

On reception, samples were stored in fridges at a temperature of 4°C until they were analysed.

Samples placed in the aerobic environment for both three and twelve months periods, were analysed with the following systems:

- Photography
- X-Ray
- Scanning Electron Microscopy
- Light Microscopy
- Identification of marine borers
- Weight Loss
- Wood Density

Description of the analyses

Photography

All samples were digitally photographed on reception (Fig.2.3). Those wrapped in Terram bags were photographed both with and without the geotextile cover. Blocks were photographed first with sediment and fouling organisms resulting from the exposure to the site environment. They were then carefully cleaned, and photographed again.



Figure 2.3. Samples photographed on reception.

X-Ray

This procedure was used as a diagnostic tool to establish if any infestation from wood boring organisms had occurred and what stage it may have reached. Once photographed, samples were taken to the English Heritage laboratory at Fort Cumberland, Portsmouth and x-rayed (Fig.2.4).

X-Rays have proven to be very effective method for determining wood degradation. X-Ray images reflect the actual status of the timber sample, allowing the researcher to evaluate if more detailed tests are necessary or not. For example, attack from wood-

boring organisms on samples from the Burgzand Noord 10 was detected at different stages with radiography. Heavily attacked blocks were subsequently opened for species identification.

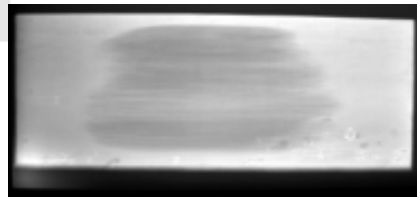

Figure 2.4. X-Ray of samples.

Scanning Electron Microscopy

To identify bacterial and fungal activity, sections of wood 0.5 cm thick were cut from source timbers (oak, pine and archaeological oak) and the surface to be studied cleaned using a double edged razor blade. Samples were prefixed in a 3% gluteraldehyde solution, washed and post-fixed in 2% aqueous osmium tetroxide overnight. They were then dehydrated through ethanol and acetone series and dried in a Polaron E3000 critical point dryer using CO₂ as drying agent. Each specimen was then mounted on an aluminium stub, coated with gold-palladium in a Polaron E 5000 diode sputter coater and examined using a Jeol JSM-6100 scanning electron microscope at 115-20 kV (McConachie, pers. Comm. 2004) (Fig.2.5).

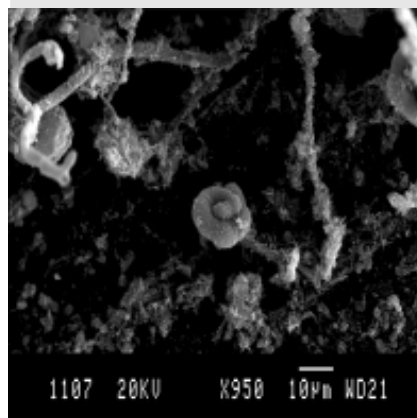

Figure 2.5. SEM of samples.

Light Stereo Microscopy

Wood blocks were examined with a Leica MZ6 Stereo Light Microscope, and images captured digitally using the Leica Q50 image analysis software. This investigation allowed detailed examination of sample surfaces and any attack from wood boring organisms (Fig.2.6). Fungal attack was also examined using this system. Where spores were visible under the Light Stereo Microscope, samples were taken, fixed on a glass slide with lactophenol (LC) and the species identified with an analytical microscope. Fungal decay on water-logged wooden samples is mainly due to soft rot fungi (Blanchette et al. 1990) which is caused by ascomycetes and deuteromycetes (Pournou 1999) and which lead to weight loss of the wood samples.

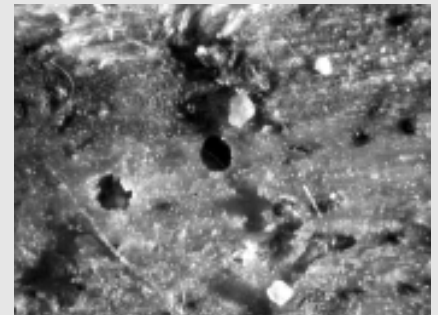

Figure 2.6. Analysis at the light microscope.

Identification of Marine Wood borers

For this investigation, samples were taken to the Marine Laboratory at the University of Portsmouth. Here specialist consultants helped in the analysis of the blocks to identify the fungi and marine borer species attacking the wood (Fig. 2.7 and 2.8).

The degree of attack on sample blocks was assessed by visual examination, as well as by using a dissecting microscope. The degradation rate was evaluated based on the extent of the galleries dug by these organisms into the wooden samples, over the given period of

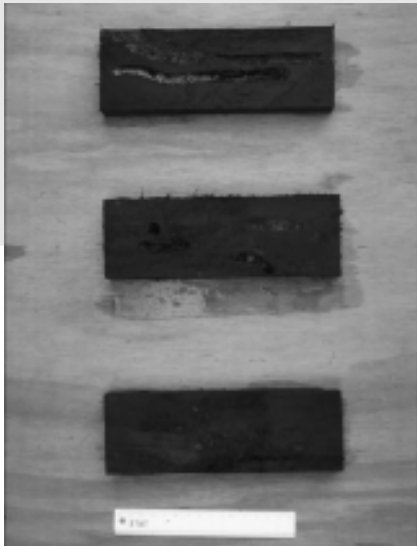

Figure 2.7. Cross sections of samples attacked by shipworms.

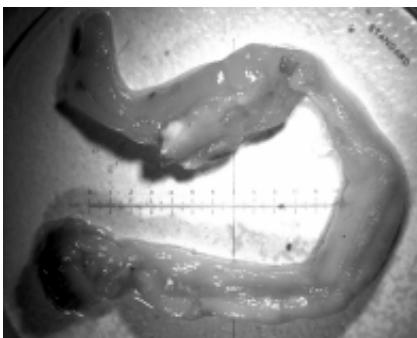

Figure 2.8. Specimen of Teredo found on samples.

exposure on site.

A point-rating scheme described by the British Standard (EN 275:1992) for attack by Teredinids, was adopted (Table 2.1).

Moisture Content

To determine the level of biological degradation at each wreck site, moisture content of the samples is one of the most important factors to consider. As wood boring organisms, fungal attack and bacteria create cavities inside the waterlogged wood its permeability increases, augmenting the void volume, which is

Grade No.	Description of condition	Condition and appearance of test wood sample
0	No attack	No sign of attack
1	Slight attack	Single or few scattered tunnels covering not more than 15% of the area of the specimen as it appears on the X-ray film
2	Moderate attack	Tunnels covering not more than about 25% the area of the specimen as it appears on the X-ray film
3	Severe attack	Tunnels covering between 25% and 50% the area of the specimen as it appears on the X-ray film
4	Failure	Tunnels covering more than 50% the area of the specimen as it appears on the X-ray film

Table 2.1. British Standard (EN 275:1992) scheme for evaluating attack by teredinis.

eventually filled with water.

Once the samples had been retrieved and the surface sediment washed away, they were weighed and then oven-dried overnight at a temperature of 105°C and weighed again. This process was repeated until the weights were stable.

Moisture Content was then determined using the following equation (Kollmann and Côté, 1968):

$$\text{Moisture Content} = \frac{\text{Wet weight} - \text{Dry weight}}{\text{Dry weight}} \times 100$$

Equation 1. Formula for moisture content calculation.

Wood Basic Density

Basic density (R) is, together with moisture content, another factor indicating the level of waterlogged wood degradation. The higher the moisture content, the lower the density. Basic density was calculated utilizing the oven-dried weight and wet volume. The following formula was applied (Panshin and De Zeeuw, 1980) to calculate basic density on samples placed in anaerobic envi-

ronment:

$$R = \frac{\text{Oven-Dried Weight}}{\text{Wet Volume}}$$

Equation 2. Basic wood density.

Wood density on samples in the aerobic environment was calculated using the following formula:

$$R = \frac{1}{(U_{\max}/100) + (1/1.5)}$$

Equation 3. Basic wood density.

Where U_{\max} = Moisture content of sample (Equation 2)

1.5 = Average density of wood cell wall material (Kohdzuma et al., 1996).

From the literature¹, the basic density value for seasoned pine is around 0.50 and for seasoned oak is around 0.70.

Nuclear Magnetic Resonance

The chemistry of waterlogged wood varies under the influence of burial conditions such as water chemistry and presence of degrading organisms. NMR is an extensively used method for the chemical analysis of wood, providing detailed analyses of

¹ BRE 1972 for pine and BRE 1977 for oak

the major carbon forms that can be linked to different lignin components. This technique provides information about the loss of wood components as well as the chemical transformation of the residual components (Hedges, 1990).

From the original sample, a section of wood of roughly 7.5 x 3 x 2.5 cm is cut away and oven-dried at a temperature of 50°C. It is then cut into small fragments and subsequently milled and sieved.

This is a very expensive test and the preparation of each sample has to be carefully carried out to avoid contamination from different components.

2.4 Analyses of samples placed in the anaerobic environment

To assess the processes that occur beneath the sediment in an underwater environment, the approach chosen for the MoSS Project has been to bury blocks of oak and pine in the proximity of each wreck site. To facilitate placement and collection, samples were assembled in rows and housed within plastic pipes with drilled holes. In total 840 small samples (5x2.5x3cm) were used and collection was scheduled at intervals of 3 and 12 months. Underwater conditions, where limited presence of oxygen occurs, may determine the degradation rate of buried wood.



Figure 3.1. Samples left in situ for 3 months.

Erosion and tunnelling bacteria are likely to be found in these conditions (Blanchette et al. 1990). The collection of samples at regular intervals may identify when the attack was initiated and the rate at which it proceeds.

On samples placed in anaerobic environment for 12 months, SEM analysis and wood density have been conducted.

Chapter 3: Results

3.1 Vrouw Maria: Samples in the aerobic environment

Photography

Samples were photographed on reception after 3 months and 12 months of exposure on site.

At a visual level, samples exposed for 3 months (Fig.3.1) were shown to be almost devoid of sedimentation or any form of attack. Occasionally, small amounts of algae were recorded, as were traces of marine fungi on unprotected control samples.

In Figure 3.2 Pinus sylvestris control samples (left) and Terram covered samples exposed for 12 months are shown. Again, no signs of degradation are visibly detectable.

On closer examination, 12 months samples did show limited sedimentation and presence of fungal activity.

X-Ray

Samples exposed for 3 months and 12 months have been X-rayed (Fig. 3.3 and 3.4), both sets showing no evidence of woodborer attack. Occasional white dots are visible on sample surfaces, though their interpretation is unclear. It is possible they represent initial woodborer coloni-

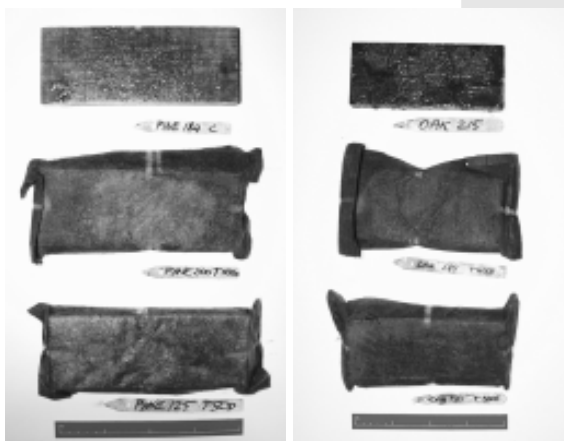

Figure 3.2. Samples left in situ for 12 months.

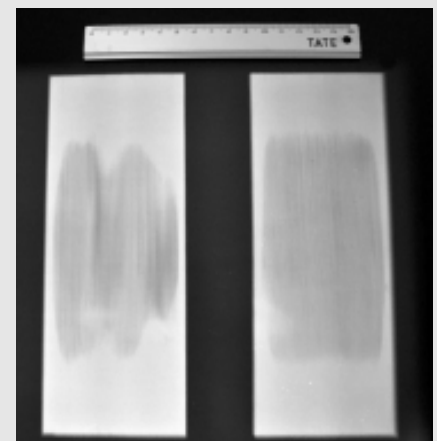

Figure 3.3. X-Ray of samples after 3 months.

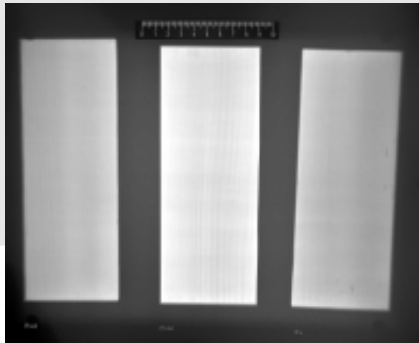

Figure 3.4. X-Ray of samples after 12 months.

sation, though may also be traces of shelly material or trapped particles of sediment.

Scanning Electron Microscopy

SEM analysis has shown that the structure of the wood samples remains very sound after three months on the site, as shown in Figure 3.5 per Pine sample. Nevertheless, presence of bacteria has been found at a superficial level, though bacteria have not penetrated the wood cells. Fungal hyphae (filaments) have also been noticed, shown here within the vessels of an oak sample (Fig.3.6).

After 12 months on site, both pine and oak samples have shown signs of degrading bacteria and fungi (Fig 3.7, 3.8). Bacteria have penetrated the cell walls and significant changes have occurred at a structural level close to the sample surfaces. Wood structure has been damaged by this activity.

Light microscopy

A representative number of samples left on site for 12 months, have been analysed under the light microscope. Results are summarised in table 3.1, where it can be seen that all samples analysed have been colonised by marine fungi.

Once marine fungal attack was recognized under the light microscope, specimens were removed with for-

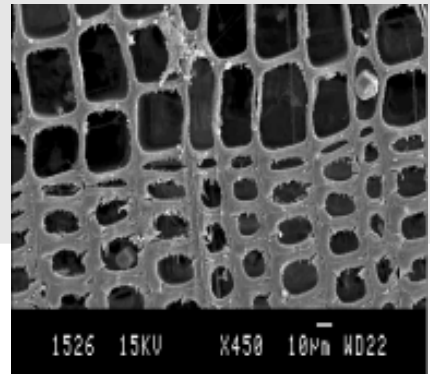
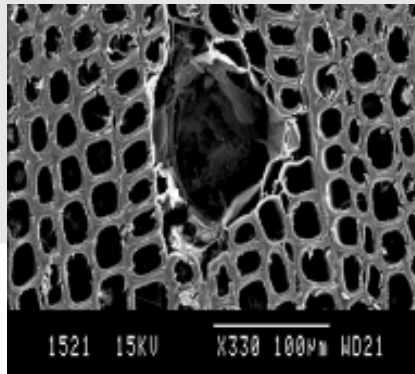

Figure 3.5. Transverse section of pine: resin canal on the left and early wood / late wood transition on the right.

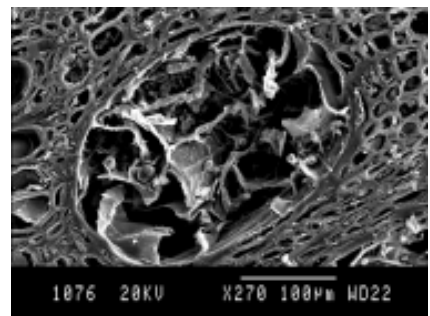
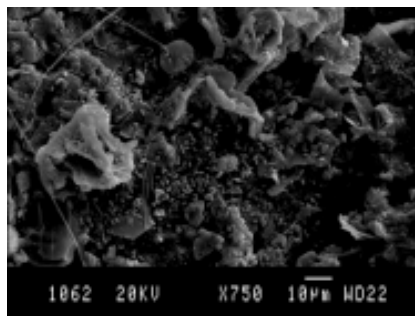

Figure 3.6. Oak samples: presence of bacteria on the left and tyloses in a vessel on the right.

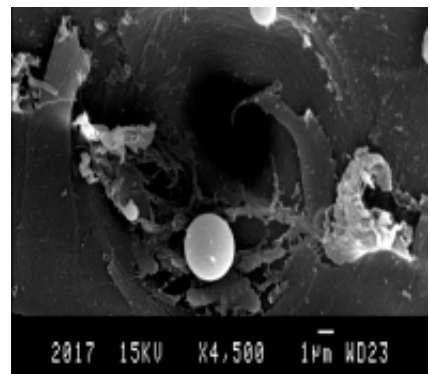
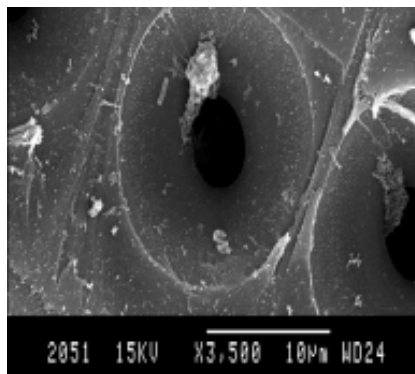

Figure 3.7. Pine samples: presence of bacteria within pit on the left and advanced degradation of pit borders on the right.

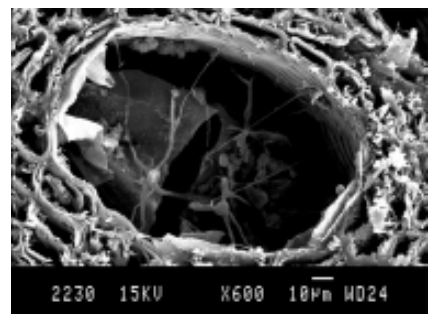
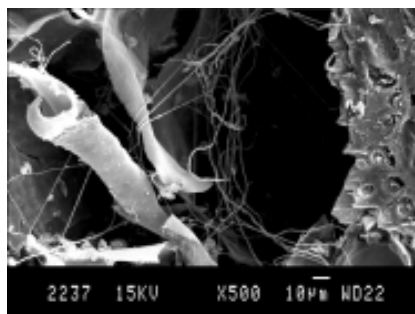

Figure 3.8. Growth of fungal hyphae within oak vessels.

ceps, mounted on glass slides in lactophenol and examined using a

dissecting microscope.

A tabulated summary of spores taken

Wood	Sample	T/C	Observations
PINE	124	500	Marine fungal attack
	199	1000	Marine fungal attack, algae
	159	2000	Marine fungal attack on surface
	109	4000	Marine fungal attack
	188	C	Marine fungal attack
OAK	169	500	Marine fungal attack. Sample has soft surface and fungal penetration is quite extensive
	59	1000	Sample very dark with marine fungal attack which has penetrated quite extensive
	149	2000	Marine fungal attack, superficial
	184	4000	Marine fungal attack, superficial
	214	C	Marine fungal attack, superficial
	MR20		Marine fungal attack has penetrated inside the sample. Small holes are visible on surface. Gelatinous algae.
	203	2000	Marine fungal attack

Table 3.1. Summary of light microscope observations for 12 months samples.

Humicola alopallonella
Trichocladium achrasporum or constrictum
 Hyphomycetes with spores
 Mixed group of *Trichocladium*
Periconia prolifica
Conidia of Cirrenalia macrocephala in fecal pallets
Trichocladium alopallonellum
Periconia sp.
 Fruiting body *Ascomata cliestothecial*

Table 3.3. Fungal species identified.

from sample surfaces is given in table 3.2. The range of species found is then shown in Table 3.3. Identification was based on the keys of Kohlmeyer and Kohlmeyer (1991) and Hyde and Pointing (2003).

All species identified, as summarized

VM 12 months	Sample number	Level of attack
	P110	0
	P125	0
	P184	0
	O215	0
	O150	0
	O185	0
	P160	0
	P200	0
	P184	0
	MR36	0
	O136	0
	O170	0

Table 3.4. List of oak and pine samples analysed for wood borer attack.

P161t2	<i>Humicola alopallonella</i>	x400	20,04 µm
P161t2	<i>Trichocladium nypae</i>	x400	28,56 µm
P161t2	<i>Trichocladium achrasporum or constrictum</i>	x400	44,88 µm
P161t2	Hyphomycetes with spores	x100	
P161t2	Mixed group of <i>Trichocladium</i>	x400	
P161t2	<i>Periconia prolifica</i>	x400	14,08 µm
P201	Conidia of <i>Cirrenalia macrocephala</i> in fecal pallets	x100	
P201t1	<i>Trichocladium alopallonellum</i>	x250	16,5 µm
O186t4	<i>Periconia sp.</i>	x100	8,1 µm
O186t4	<i>Trichocladium alopallonellum</i>	X	24,3 µm x100
O186t4	Fruiting body <i>Ascomata cliestothecial</i>	x250	72,9 µm
O186t4	<i>Trichocladium alopallonellum</i>	x250	-
O186t4	Structure with spores	x100	
MR42	<i>Trichocladium ligni</i>	x250	50,5 µm
MR42	<i>Ceriosporopsis circumvestita</i> 2 spores with hyphae	x250	15.5 µm 33.0 µm
MR42	<i>Cleistothecial</i> (structure with spores)	x250	99,0 µm
MR42	Spores (<i>Trichoc. sp mostly</i>)	x100	

Table 3.2. Fungal spores collected from 12 months samples.

3 months	Moisture Content	Density	12 months	Moisture Content	Density
VM 3m P182	170.3	0.42	VM 12m P184	204.4	0.37
VM 3m P123	160.8	0.44	VM 12m P125	162.6	0.44
VM 3m P197	170	0.42	VM 12m P200	158.2	0.44
VM 3m P158	167.2	0.43	VM 12m P160	145.3	0.47
VM 3m P108	146.5	0.47	VM 12m P110	208.1	0.36
VM MR22	122.3	0.53	VM MR36	125.2	0.52
VM 3m O211	77.9	0.69	VM 12m O215	167.7	0.43
VM 3m O168	70	0.73	VM 12m O170	162.1	0.44
VM 3m O56	75	0.71	VM 12m O136	162.3	0.44
VM 3m O146	94.7	0.62	VM 12m O150	121.2	0.53
VM 3m O182	90.3	0.64	VM 12m O185	167.7	0.43

Table 3.5. Moisture Content and Wood Density of 3 and 12 months samples.

VM = Vrouw Maria

P + no = Pine + identification number of the sample

O = Oak + identification number of the sample

MR = Archaeological Wood

3m = 3 months period on site

12m = 12 months period on site

Moisture Content

The degradation of both 3 and 12 month samples is not extensive and should have produced little changes in moisture content values (Table 3.5). Given this, the natural variation of MC throughout the sample group and having only two data points, limits of the usefulness of MC data at this stage. MC data is presented only to illustrate an overall trend of increasing MC, though changes are small and potentially misleading.

Table 3.5 also shows wood density values calculated on the samples placed in aerobic environment for 3

and 12 months, calculated from MC data using the maximum MC method (Equation 3). Here, values are close to those expected and indicated by the literature, as specified on page 12.

3.2 Samples placed in the anaerobic environment

Scanning Electron Microscopy

SEM analyses have been conducted on sections cut out of samples placed in the anaerobic environment and the outcome is a distinctive degradation pattern from bacteria (see

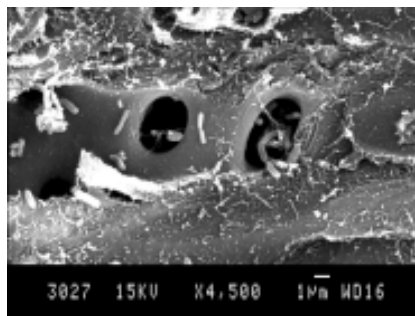
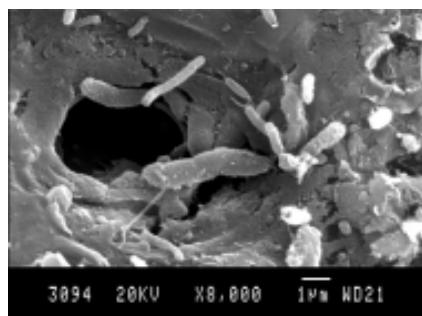

Figure 3.9. Pine and oak samples colonised by bacteria.

¹All samples were delivered to the partners at the same time, with the intention of placing them on site at the same time. Unfortunately, weather conditions did not allow collection of the 1st set of samples after 3 months. Instead, they were returned 5 months from their initial placement on site.

Wood	BD Row 1	BD Row 2
Oak		0.49
Oak	0.47	
Oak	0.55	
Oak	0.45	
Oak		0.52
Wood	BD Row 1	BD Row 2
Pine	0.41	
Pine		0.46
Pine		0.38
Pine		0.39
Pine	0.38	

Table 3.6. Basic Density.

Figure 3.9) on both pine and oak samples.

Basic density of wood

In Table 3.6, basic density values are reported calculated on the samples placed in the anaerobic environment for 12 months. The Basic Wood Density was calculated using the Equation 2.

It is to be noted, that these values are below the expected average (compared to those indicated by the literature). This may be due to the fact that the team had decided to place the samples horizontally instead of vertically and possibly conditions were not fully anaerobic, because of the difficulties in excavating the hard sediment on the Vrouw Maria site.

3.3 Darsser Kogge: Samples in the aerobic environment

Photography

Samples were photographed on reception after five¹ and twelve months of exposure on site.

After five months on site (Fig.3.10) pine, oak and archaeological oak control samples already showed changes in condition and were being colonized by marine fouling organisms such as barnacles, bivalves and algae. Samples wrapped in the

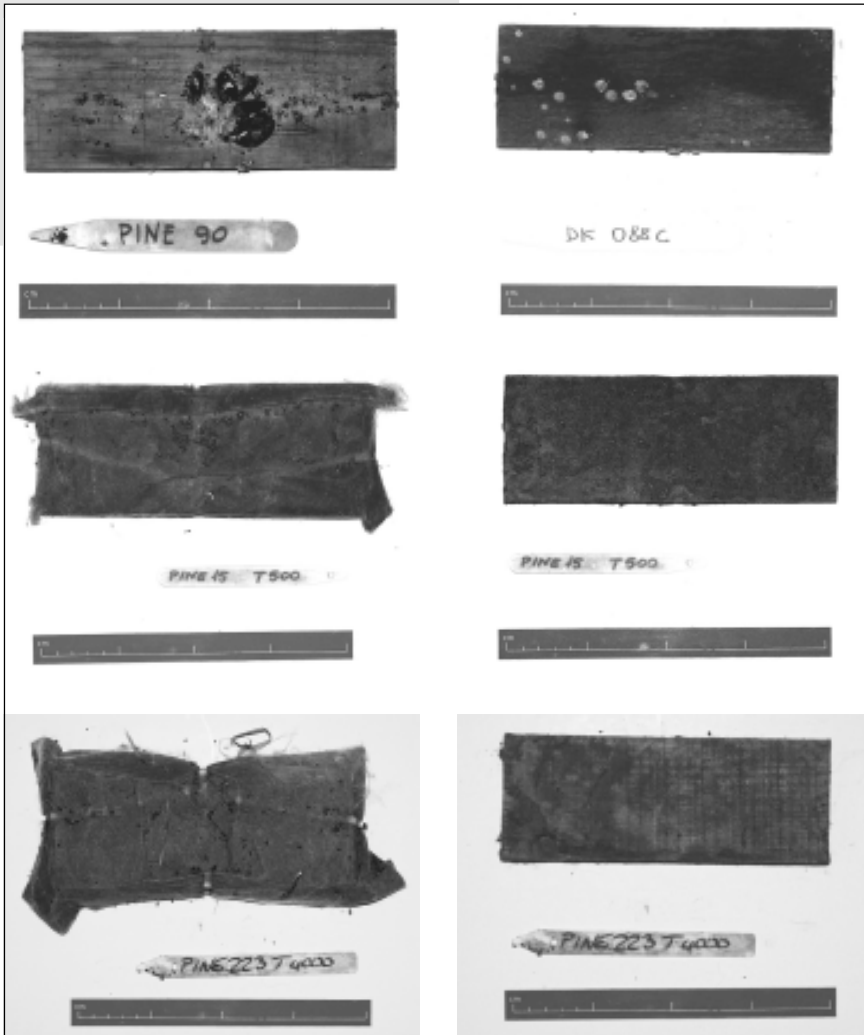

Figure 3.10. Samples placed in the aerobic environment for 5 months.

geotextile “bags” proved to be in better condition than controls. Lower grade of geotextile (T500) allowed only fine sediment to enter into the bag, almost completely covering the sample surface. Higher grades of geotextile (T4000), allowed little sedimentation within the “bag”, leaving the sample clean or covered only superficially with fine sand. No difference was observed in condition of oak and pine samples.

X-Ray

Samples exposed for 5 months were seen to be free from woodborer attack after x-ray analyses (Fig.3.11). On

two samples (one control and one wrapped in geotextile grade 2000) small white dots were present. The interpretation is difficult as these dots could be due to the resolution of the x-ray or some technical faults. Alternatively these could be traces of small shells or grains of sediment. Ultimately, but not confirmed, this could be interpreted as a first sign of infestation from wood boring organisms.

Pine samples that have been x-rayed after twelve months of exposure on site show small shadows or again, small white dots. Figure 3.12 shows

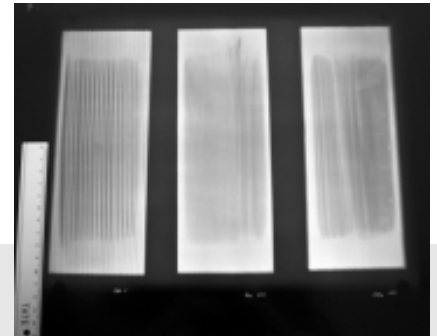

Figure 3.11. X-Ray of samples after 5 months on site.

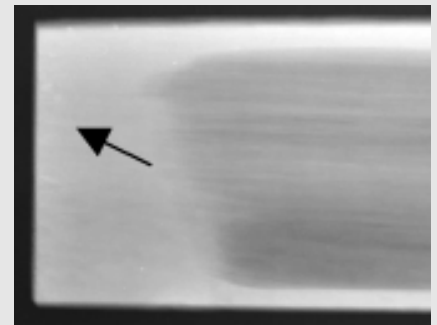

Figure 3.12. X-Ray of a sample after 12 months on site.

whiter areas on the left hand side on a control pine sample surface (indicated by black arrow). This may be interpreted as initial attack. Attack by Teredo happens through the grain, since these organisms find it easier to dig tunnels inside the timber following the grain of the wood.

The x-ray on oak samples, with the exclusion of the control one, register the presence of white dots.

Scanning Electron Microscopy

On the 5 month samples, wood degradation within pits on pine samples is quite advanced, whereas on oak samples, fungal attack is evident but the overall cell structure remains intact.

In Figure 3.13 bacteria are visible and in Figure 3.14 wood degradation by bacteria is advanced.

Wood degradation is quite extensive on samples after 12 months of exposure on site. Fungal and bacterial

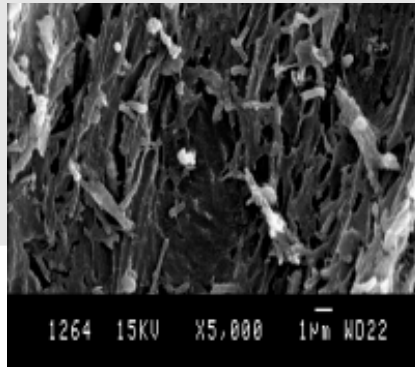
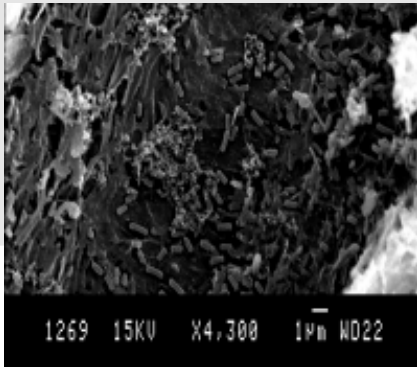

Figure 3.13. Bacterial infestation on Pine control samples.

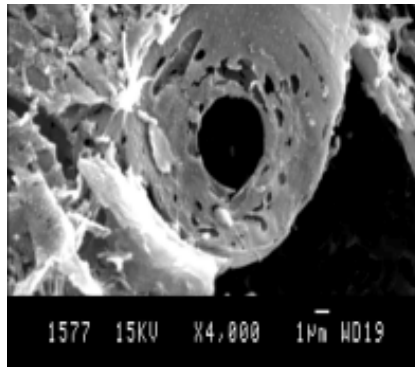
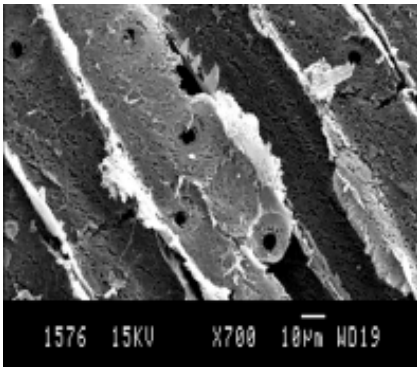

Figure 3.14. Bacterial attack on Pine samples wrapped in geotextile 500.

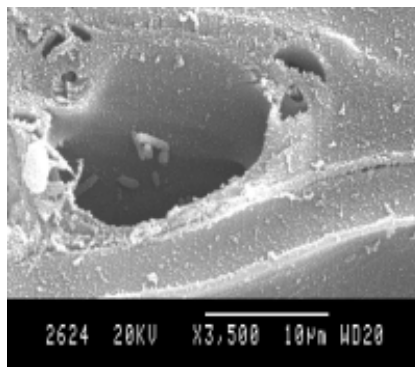
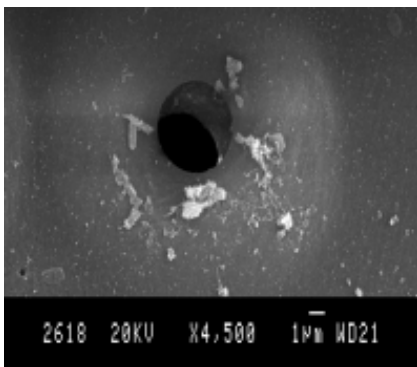

Figure 3.15. Pine samples: Presence of bacteria in ray parenchyma and outside pits.

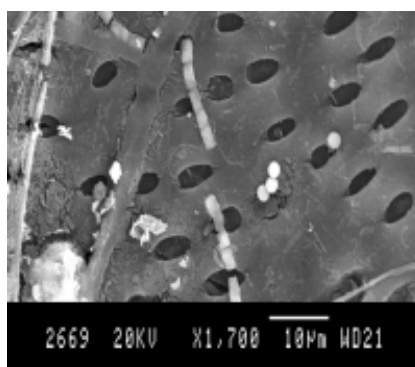
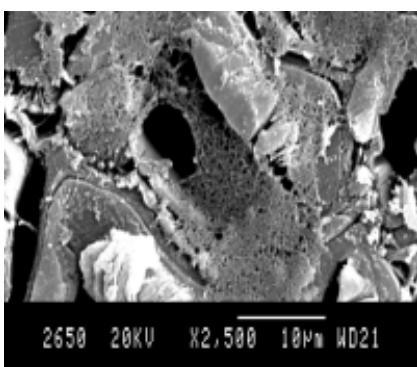

Figure 3.16. Pine samples: bacteria inside pits.

Figure 3.17. Oak samples: bacterial and fungal attack in vessels.

degradation is evident in both pine and oak samples (Fig. 3.15, 3.16, 3.17) and it is interesting to note that different geotextile grades had little influence on the degree of degradation, all samples showing a similar level of attack.

Light microscopy

A representative number of samples left on site for 5 and 12 months were analysed using the light microscope. Results, where by fungal marine attack and the beginning of wood-borer colonisation are visible, are summarized in the Table 3.7.

Once marine fungal attack was recognized using light microscopy, specimens were removed with forceps, mounted on glass slides in lactopheno and examined using a dissecting microscope. A tabulated summary of spores taken from sample surfaces is given in Table 3.8 (page 20). The range of species found is then shown in table 3.9. Identification was based on the keys of Kohlmeyer and Kohlmeyer (1991) and Hyde and Pointing (2003).

All species, which are listed in table 3.9 are identified as soft rot fungi.

Identification of marine borers

Almost all samples, both control and those wrapped in geotextile, showed some level of initial attack, as revealed by examination using the dissecting microscope.

This contrasts with the radiographs, which didn't show any attack, unless again the small white dots are interpreted as initial infestation.

Table 3.10 shows the level of attack on the samples as revealed by radiograph images, utilising the Point Rating Scheme used by The British Standard (EN 275:1992) as indicated in table 2.

Wood type	Sample	T/C	Microscope analysis 5 months
PINE	13	500	Marine fungal attack
	42	1000	Marine fungi like attack; presence of algae and barnacles
	224	4000	Marine fungal attack
	88	C	Marine fungal attack & filamentous algae
OAK	13	1000	Marine fungal attack
	28	2000	Marine fungal attack
	133	4000	Marine fungal attack
	44	500	Marine fungal attack
PINE	64	2000	Marine fungi on the edges
	MR31		Small holes on surface. No evidence of fungal or woodborer attack
OAK	89	C	Marine fungal attack
Wood type	Sample	T/C	Microscope analysis 12 months
PINE	34	1000	Marine fungi attack. No woodborer attack
OAK	4	1000	Completely infested by marine fungi. No woodborer attack
	19	2000	Marine fungi attack. No woodborer attack.
	79	C	Marine fungi attack. Presence of barnacles. No woodborer attack
	MR45		Presence of marine fungi. Few small holes from woodborer attack. The sample is very dark and covered with fecal pellets. It is difficult to see underneath if there are more holes
PINE	20	2000	Molluscs, bivalves and marine fungi are present. No woodborer attack
	215	4000	Presence of marine fungi. No woodborer attack.
	80	C	Marine fungi with fruiting bodies are present. Barnacles and brown algae. No woodborer attack
	6	500	Woodborer holes are present

Table 3.7. Summary of light microscope observations for 5 and 12 months samples.

<i>Ascomata perithecial</i>
<i>Zalerion sp</i>
<i>Cliestothecial</i>
<i>Cirrenalia macrocephala</i>
<i>Ceriosporopsis circumvestita</i>
<i>Periconia prolifica</i>
<i>Monodyctis pelagica</i>

Table 3.9. Fungal species identified.

DK 1y	Sample number	Level of attack
	O5	0
	O20	0
	No Number	0
	O34	0
	MR3	0
	O80	0
	P216	0
	P19	0
	O80	0
	P4	0
	P36	0
	P81	0

Table 3.10. List of oak and pine samples analysed for wood boring attack.

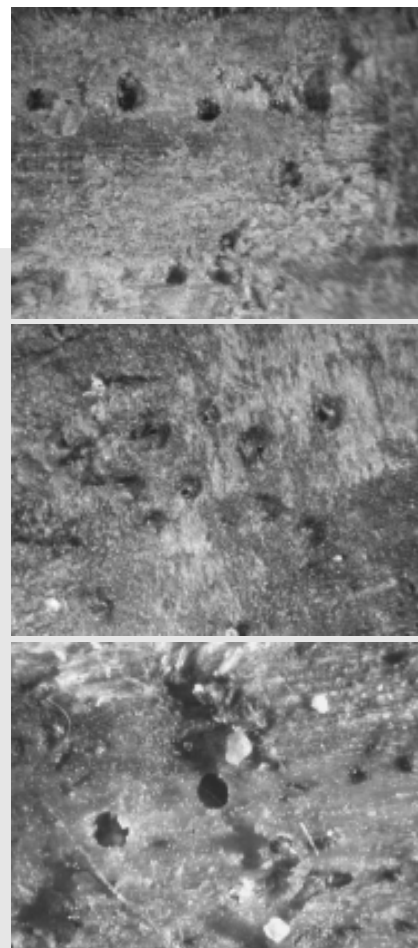

Figure 3.18. Initial infestation by wood borers, seen under the light microscope.

It should be mentioned that the British Standards, defines "Slight attack" (point rating 1) as "single or few scattered tunnels covering not more than 15% of the area as it appears on the X-Ray film". Clearly the samples analysed here do not enter this category. Neither, however do they fit the "No Attack" classification (point rating 0) where there is no sign of attack at all. It has been shown that samples were colonised by woodborers, given the presence of many small holes recorded with the light microscope though not evidence was recorded with the X-Ray system. Therefore, it is to be concluded that after 12 months on site, there is an ongoing infestation, which can not

O35	<i>Ascomata penthecial</i>	x100	486 µm
P6	<i>Zalerion sp</i>	X250?	29.7
P6	<i>Cleistothecial</i>	x100	64.8 µm
O37	Structure with spores	x100	405 µm
O37	<i>Cirrenalia macrocephala</i> 4celled spore	x250	17.5 µm
P80	<i>Ceriosporopsis circumvestita</i>	x250	26,3 µm
P80	<i>Periconia prolifica</i>	x250	14 µm
P80	<i>Ceriosporopsis circumvestita</i>		
P80	<i>Monodictis pelagica</i>	x250	15,8 µm
P80	Not identified	X250	10 µm
P80	Fungal hyphae	x250	30 µm
O37	Not identified	x250	11 µm
O37	Not identified	x250	8 µm
O80	<i>Cleistothecial</i>	x250	80 µm
O80	<i>Cleistothecial</i>	x100	
O80	<i>Clistothecial</i>	x100	
O80	Not identified	x250	

O80	Not identified	x250	
O80	Not identified	x250	.9 µm
O7	Group of spores one of which is <i>Trichocl. Allopall.</i> And the others <i>Periconia</i>	x400	20 µm 20 µm
O7	<i>Trichocladium med.</i>	x400	20 µm
O7	Group of 5 spores in different stages	x400	
O37	Group of <i>Trichocladium med</i>	x400	16 µm 16 µm 20 µm
O37	Black structure + spore	x400	44 µm 10 µm
O37	Black structure with spores emerging	x400	36 µm
O37	Not identified	x400	20 µm
P36	<i>Trichocladium med</i>	x400	18 µm
P36	<i>Cirrenalia pygmaea?</i>	x400	22 µm
P36	Group of 3 spores	x400	18 µm
P36	<i>Monadictys Pelagica</i>	x400	30 µm
P215	Fruiting body with emerging spore	x400	30 µm
P215	<i>Trichocladium med.</i> X	x400	22 µm
O19	<i>Periconia</i>	x400	18 µm

Table 3.8. Fungal spores collected from 12 months samples.

quite be defined as attack, because no tunnels have been detected by the X-Ray analysis. Nevertheless, this represents a clear stage of transition from initial infestation, where holes are present and borer shells and pallets could be identified, to attack where tunnels are more prominent. It is the opinion of the writer that the importance of this early stage should not be underestimated. It marks the point of initial infestation, after which further attack will progress rapidly.

Moisture Content

Moisture content values were calculated for the 5 and 12 months samples. (Table 3.11). Again it should be stressed that this interval is only sufficient to see an initial trend. As mentioned before, a more accurate system should have used replicates, and having only two data points, limits the usefulness of MC data at this stage. The degradation of both 5 and 12 months samples is not extensive and should have produced little changes in moisture content values (Table 3.11). MC data is presented only to illustrate an overall trend of increasing MC, though changes are small and potentially misleading. The use of only 2 data points over 12 months cannot be considered indicative of overall trends.

Table 3.11 also shows wood density values calculated on the samples placed in the aerobic environment for 5 and 12 months, from MC data using the maximum MC method (Equation

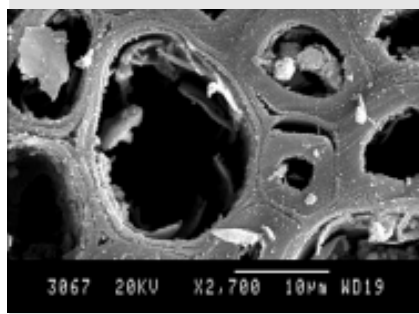

Figure 3.19. Presence of bacteria on pine and oak samples in anaerobic environment.

Samples	Moisture Content	Basic Density	Samples	Moisture Content	Basic Density
DK 5m P88	134.1	0.50	DK 12m P79	157	0.45
DK 5m P13	236.7	0.33	DK 12m P4	157.1	0.45
DK 5m P42	104.4	0.58	DK 12m P36	-	-
DK 5m P64	184.4	0.40	DK 12m P19	172.5	0.42
DK 5m P224	148.3	0.47	DK 12m P216	177.3	0.41
DK 5m O89	89.5	0.64	DK12m O80	103.2	0.59
DK 5m O44	120.9	0.53	DK12m O34	260.2	0.31
DK 5m O13	111.1	0.56	DK12m O5	111	0.56
DK 5m O28	86.9	0.65	DK12m O21	61.6	0.78
DK 5m O133	103.8	0.59	DK12m O125	85.7	0.66
DK MR31	116.3	0.55	DK 12m MR3	84	0.66

Table 3.11 Moisture Content and Wood Density of 5 and 12 months samples

Above the samples have been coded as it follows:

DK = Darsser Kogge

P+ no = Pine + identification number of the sample

O = Oak + identification number of the sample

MR = Archaeological Wood

C = control sample

5m = 5 months period on site

12m = 12 months period on site

3, p. 12). Here, values are closer to those expected and indicated by the literature, as specified on page 12.

3.4 Darsser Kogge: Samples in the anaerobic environment

Scanning Electron Microscopy

SEM analyses on the 12 month samples revealed a distinctive degradation pattern from bacteria on the German site.

Bacteria and fungal degradation were detected on pine and oak samples, as shown in Figures and are here visible on graphs 3.19.

Basic Density of the wood

In table 3.12, basic density values are reported, for the samples placed in

the anaerobic environment for 12 months. It is to be noted, that these values are generally below or in line with the expected average (compared to those indicated in the literature (see page 12).

Wood	BD Row 1	BD Row 2
Oak	0.56	
Oak		0.53
Oak		0.52
Oak		0.53
Oak	0.58	
Wood	BD Row 1	BD Row 2
Pine		0.38
Pine	0.40	
Pine	0.36	
Pine	0.44	
Pine		0.40

Table 3.12. Basic Density.

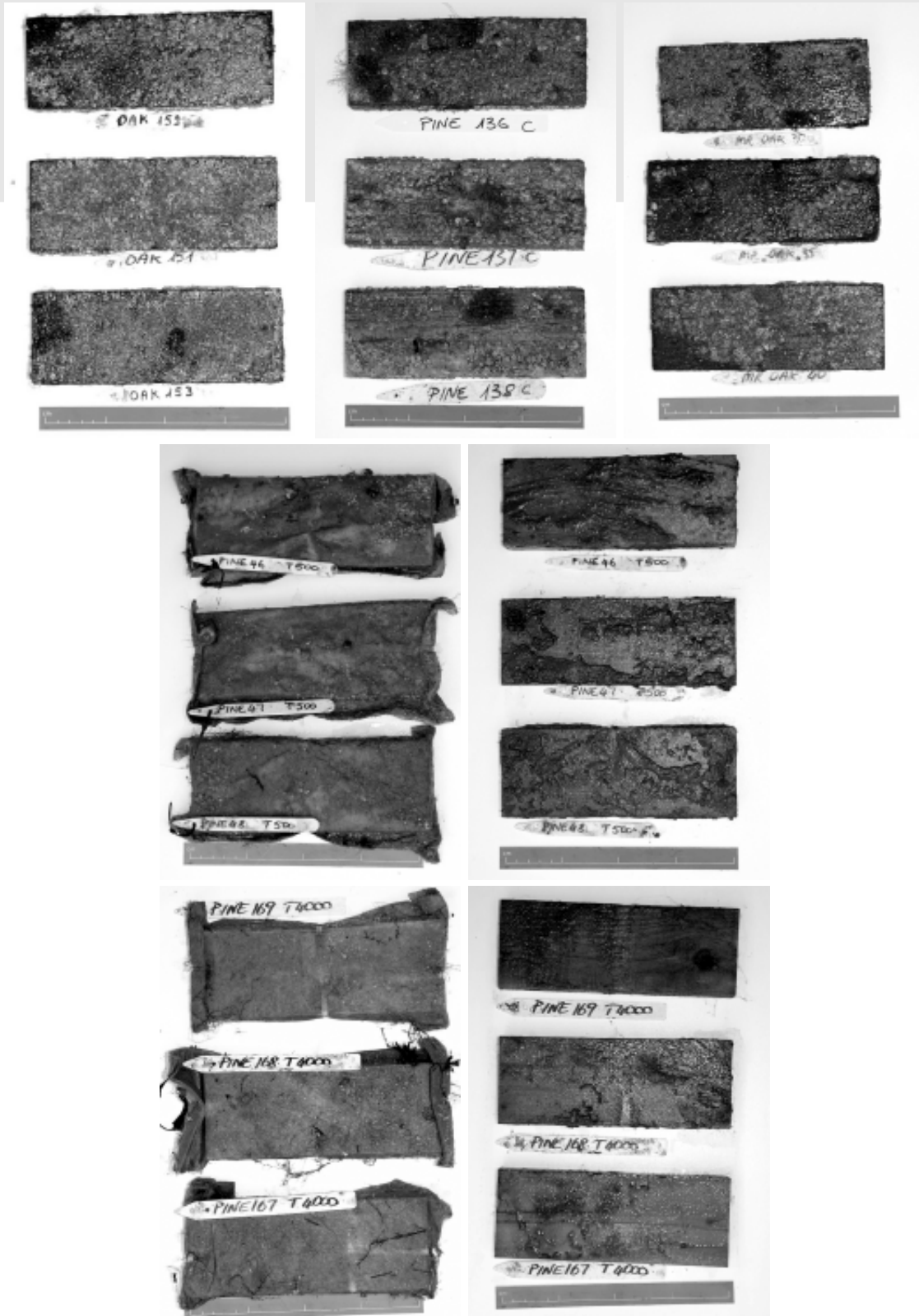

Figure 3.20. Samples placed in aerobic conditions with sediment on the surface.

3.5 Burgzand Noord 10: Samples in the aerobic environment

Photography

Samples left in aerobic environment for three months were subjected to extensive colonisation by marine organisms, as well as heavy sedimentation.

Control pine, oak and archaeological wood left for 12 months were extensively colonised by barnacles to a level where nearly all the wood surface was covered. This reflects the dynamics and activity of the site conditions; hypothetically, a thorough hard calcareous covering of barnacles could provide a “screen” against other borer attack, in the eventuality that the infestation has not already happened.

As it can be seen from the pictures (Fig. 3.20, last page), a considerable amount of sediment was trapped between all samples and the different grades of Terram. On the surface of the geotextile “bags” evidence of

barnacles, algae, bivalves and other marine organisms has been recorded. After twelve months on site, samples were completely covered by sediment within the geotextile bags. Also a very distinctive strong smell of hydrogen sulphide could not go unnoticed: in fact, once the Terram and the sediment were removed, the condition of the wood was seen to be very soft and spongy in some areas.

X-Ray

After three months on site, samples were x-rayed as they arrived. Sediment and barnacles present on the surface were not removed.

X-rays (Fig.3.21) – Apart from the calcareous presence of the barnacle,

x-rays show white “shadows”, that could be interpreted as initial infestation from woodborers.

X-rays taken on the 12 months samples show a surface covered by barnacles: this masked signs of internal attack (Fig.3.22). Once the samples have been cleaned, the x-ray image more clearly shows the pattern of borer attack (Fig.3.23 and 3.24).

All pine samples placed on site for 12 months show different levels of attack decreasing with thickness of the geotextile grades used. Oak samples seemed free of attack, though some white “shadows” are visible on the radiographs.

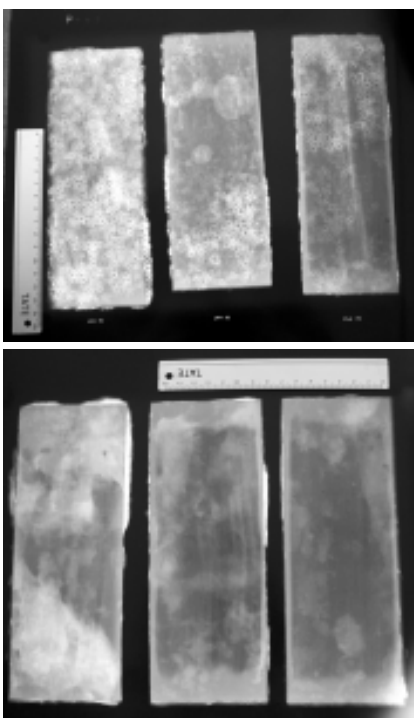

Figure 3.21. X-rays of 3 month samples.

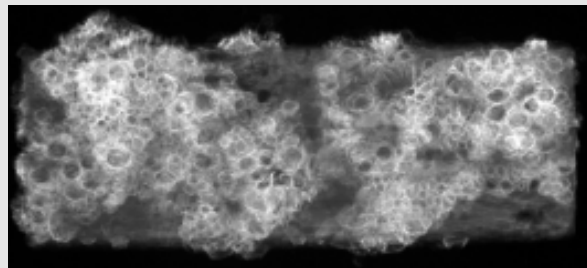

Figure 3.22. X-Ray of control sample showing the surface covered by barnacles.

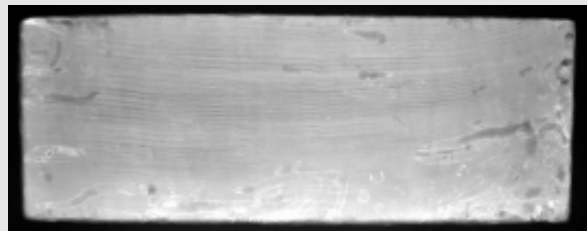

Figure 3.23. X-Ray of oak sample (12 months) showing wood borer attack once barnacles were removed.

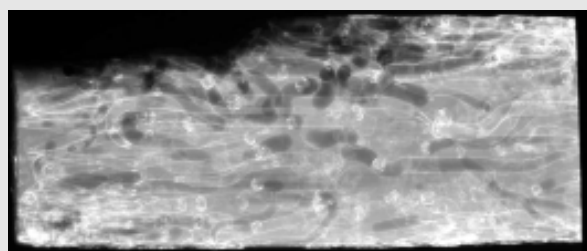

Figure 3.24. X-ray of a pine sample, showing a high level of attack by woodborers.

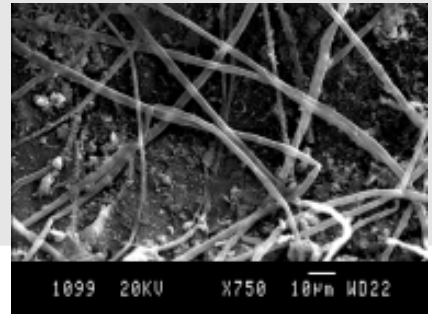
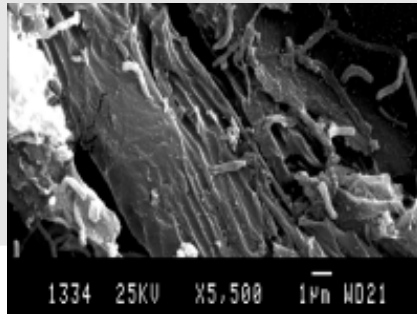
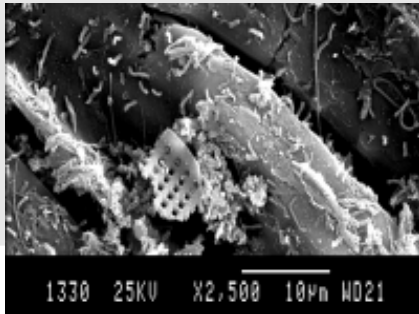

Figure 3.25. SEMs of oak samples after 3 months, control (left) and wrapped in geotextile (right), showing bacteria and fungal degradation.

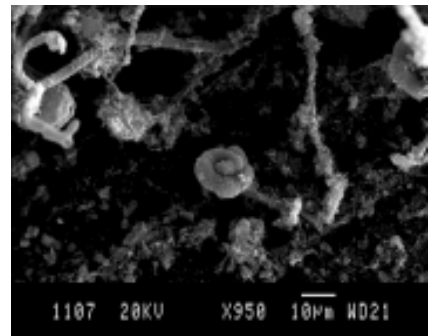
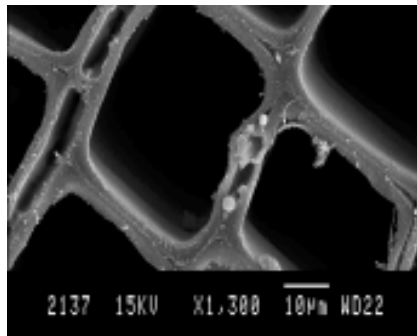
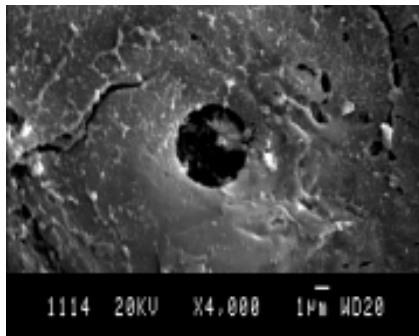

Figure 3.26. SEMs on pine samples showing bacterial and fungal attack.

Scanning Electron microscopy

Overall the wood structure seems sound at a superficial level. However, at higher magnification, extensive degradation by bacteria is evident on both pine and oak samples, regardless of the grade of geotextile they were wrapped in. This degradation is already visible on samples left on site for 3 months (Fig.3.25).

to the naked eye) to quite advanced attack on the 12 months samples (internal structure severely damaged).

Once marine fungal attack has been recognized using light microscopy, specimens were removed under the

Micrographs of samples left on the site for 12 months (Figure 3.27) are helpful not only in the investigation of the wood structure, and the presence of fungal and bacterial attack, but also to see, at a higher magnification, the damage caused by shipworms.

Light microscopy

A representative number of samples left on site for 3 and 12 months, have been examined under the light microscope. Results, as reported in Table 3.13, show that colonisation from woodborers goes from being at an initial stage after 3 months (only small superficial holes, not detectable

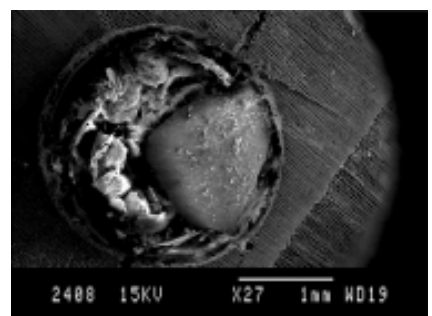
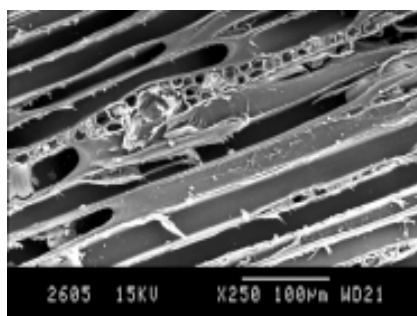
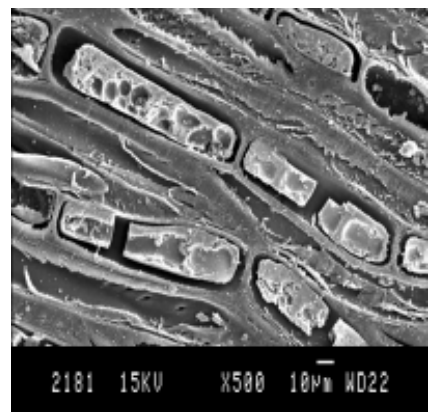
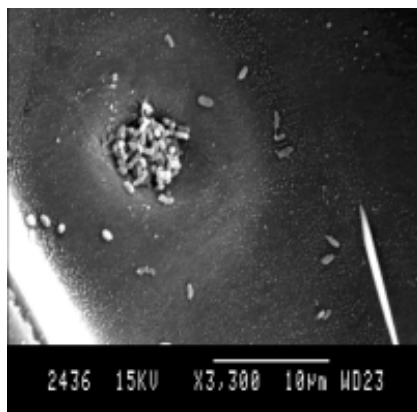

Figure 3.27. SEMs on pine and oak samples showing bacterial infestation and borer attack.

Wood type	Sample	T/C	3 months
PINE	66	2000	Found no presence of woodborer attack. Presence of marine fungi.
	136	C	Little superficial holes – proven to be <i>Teredo Navalis</i> . One small hole shows evidence of the initial attack where the cone with two small holes (broken) for the siphons are visible. In some of the holes the attack has gone further inside the panel.
	47	500	Found presence of w/b attack. Quite a lot of holes are present but very small almost not visible to the naked eye. Some holes have been dug inside the panel. Presence of marine fungi.
	92	1000	Found presence of w/b attack at superficial level (around 10 holes) only on one flat surface. Marine fungi have been noticed
OAK	61	1000	No w/b attack. Presence of marine fungi.
	91	2000	No w/b attack. Marine fungi are. Sample v. dark on surface. Presence of marine fungi.
	151	C	Surface completely attacked by barnacles but evidence of calcareous lining has been found as well as small holes difficult to see because of the presence of a lot of sediment. Wood is quite rotten superficially
	MR30		Little superficial holes – proven to be <i>Teredo</i> 's. These are only on one surface. Presence of marine fungi.
PINE	137	C	Surface completely attacked by barnacles but evidence of calcareous lining has been found as well as small holes difficult to identify because of the presence of a lot of sediment. Small black spheres (marine fungi?) have been found in great quantity.
	93	1000	No w/b attack. Presence of marine fungi.
	68	2000	No w/b attack.
	169	4000	No w/b attack. Presence of marine fungi.
	MR40		Surface completely attacked by barnacles but evidence of calcareous lining has been found as well as small holes
OAK	152	C	Superficial w/b attack. Found calcareous lining in the vessels. Initial attack goes inside the panel. Presence of marine fungi
	108	500	No w/b attack
	48	4000	No w/b attack.
			12 months
PINE	140	C	Presence of a lot of superficial barnacles. Quite a lot of superficial holes are present but inside the sample is badly attacked. Quite big pallets have been extracted. Suggested level of attack 4 Proved presence of <i>Limnoria</i> .
	96	1000	Marine fungi were recorded. Few holes from woodborers very superficial.
	71	2000	Superficial marine fungi. No woodborer attack.
	172	4000	Superficial marine fungi. No w/b attack
	141	C	Few superficial w//b holes, big and small calcareous linings. Presence marine fungi. Level of attack 3.
	MR25		A lot of superficial holes from w/b attack and holes are with calcareous lining. Level of attack 3. Presence of marine fungi.
OAK	111	500	W/b holes. Low level of attack (1) at initial stage. In one of the holes there have been found pallets attached to each other
	66	1000	Superficial marine fungi. No w/b
	96	2000	No w/b. Marine fungi.
	51	4000	Superficial marine fungi. No w/b
	156	C	A lot of superficial attack from woodborers and barnacles are present. Presence of many holes with calcareous lining which are yellowish. Marine fungi. Suggested level of attack 1.

Table 3.13. Summary of light microscope observations for 3 and 12 months samples.

microscope with forceps, mounted on glass slides in lactophenol and examined under the dissecting microscope.

Identification in Table 3.14 was based on the keys of Hyde and Pointing (2003) and Kohlmeyer and Kohlmeyer (1991).

Identification of Marine borers

The dissecting microscope allowed detection of different stages of infestation and attack, from the very early phases to severe degradation.

Table 3.15 summarises the level of attack on the 12 months samples

P50t5	<i>Trichocladium medullare</i>	x100	32,4 µm
P50t5	<i>Periconia prolifica</i>	X	24,3 µm
P50t5	<i>Monodictys pelagica</i>	X	32,64 µm
O156C	Not identified	x250	40,5 µm
P171t4	<i>Periconia prolifica</i>	x100	24,3 µm
P171t4	<i>Trichocladium medullare</i>	x400	24,3 µm
P171t4	<i>Zalerion</i>	x100	23,1 µm
P171t4	Fruiting body: Perithecial	x100	
P171t4	<i>Orbimyces spectabilis</i>	x250	29,7 µm
P171t4	<i>Trichocladium</i>	X	
P171t4	<i>Monodictys pelagica</i>	x1000	35 µm

Table 3.14. Fungal spores collected from 12 months samples.

Site	Sample Number	Level of attack
BN 12 months	O155	2
	O156	1
	O111	1
	O110	0
	O95	0
	P70	0
	P171	0
	O50	0
	O65	0
	No number	1
	P95	0
	P50	0
	P140	3
	P141	2
	MR25	2

Table 3.15. List of oak and pine samples analysed for wood boring attack.

which was assessed using X-Ray images, following the point rating of the British Standards reported on page 12.

Different levels of infestation and attack is visible in Fig.3.28 and 3.29,

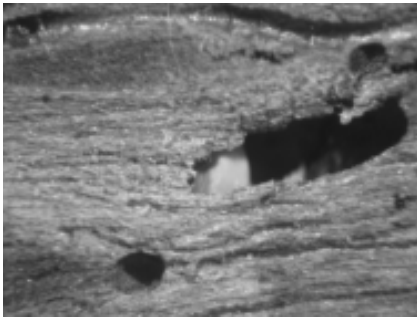
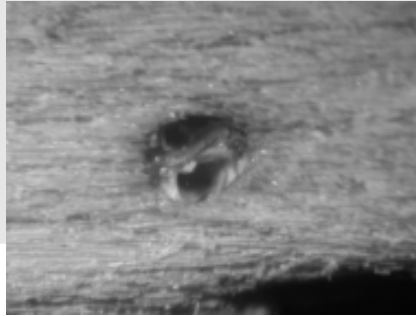

Figure 3.28. Initial shipworm infestation on pine and oak samples after 3 months.

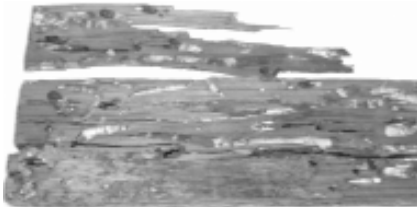

Figure 3.29. Archaeological oak and fresh pine samples degraded by shipworm after 12 months.

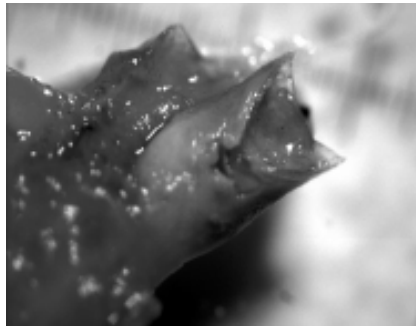
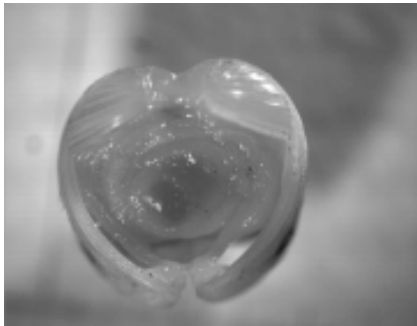

Figure 3.31. Shell and pallet of a specimen of *Teredo nautilus* found on the Dutch site.

on both pine and oak samples, after 3 months (graphs taken with microscope) and after 12 months. Some specimens were taken out of the samples for identification (Fig.3.30, 3.31) and were identified as *Teredo nautilus*.

Moisture Content

The trend of moisture content was calculated on the data from three and twelve month samples. Only two data points were available (3 and 12 months), which limits the usefulness of MC data at this stage. The degrada-

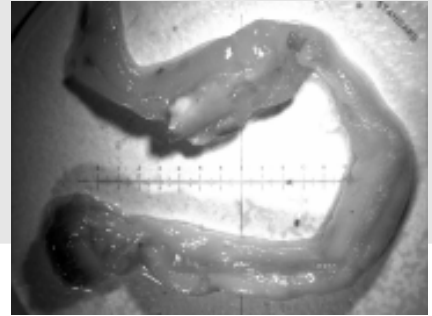

Figure 3.30. Identification of woodborers as *Teredo nautilus*.

tion of 3, and especially of 12 month samples is quite extensive. MC data is presented only to illustrate an overall trend of increasing MC, though changes are small and potentially misleading. The use of only 2 data points over 12 months cannot be considered indicative of overall trends.

Table 3.16 also shows wood density values calculated on the samples placed in aerobic environment for 3 and 12 months, from MC data using the maximum MC method (Equation 3, page 12). Here, values are closer to those expected and indicated by the literature, as specified at page 12.

Wood density was calculated for aerobic samples after 3 and 12 months on site. The values in table 3.16., for 3 and 12 months can be compared to the values from BRE 1977 and 1972, whereby the range is around 0.50 for Pine and 0.70 for oak.

Sample No.	MC	Wood Density	Sample No.	MC	Wood Density
Bn 3m P136	109.5	0.57	Bn 12m P141	157.2	0.45
Bn 3m P47	113	0.56	Bn 12m P????	missing	missing
Bn 3m P92	127.7	0.51	Bn 12m P96	149.6	0.45
Bn 3m P66	112.1	0.56	Bn 12m P71	154.2	0.73
BN 3m P169	71.6	0.72	Bn 12m P172	69.6	0.64
BN 3m O152	92.6	0.63	BN 12m O156	89.9	0.68
BN 3m O108	104.2	0.59	BN 12m O111	79.4	0.64
BN 3m O61	77.3	0.69	BN 12m O66	89	0.69
BN 3m O91	105.9	0.58	BN 12m O96	77.8	0.62
BN 3m O48	79.5	0.68	BN 12m O51	94.5	0.45

Table 3.16. Moisture Content and Wood Density of 3 and 12 month samples.

Above the samples have been coded as it follows:

BN = Burgzand Noord 10

P+ no = Pine + identification number of the sample

O = Oak + identification number of the sample

MR = Archaeological Wood

C = control sample

3m = 3 month period on site

12m = 12 month period on site

3.6 Burgzand Noord 10: Samples in the anaerobic environment

Scanning Electron Microscopy

SEM analyses have been conducted on sections cut out of these samples and show a distinctive degradation pattern from bacteria on oak and pine samples after 12 months on site (Fig.3.32).

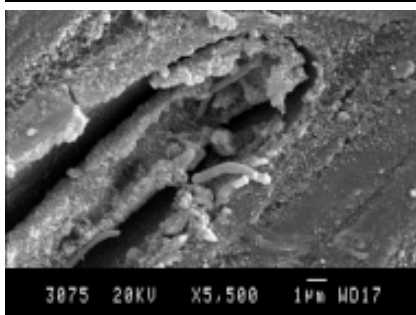
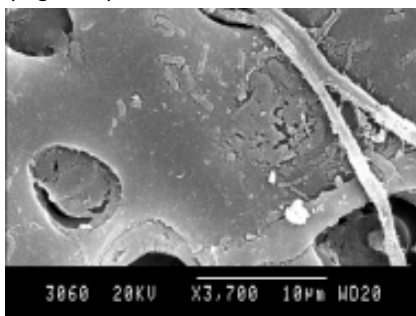

Figure 3.32. SEM of pine and oak placed in anaerobic environment showing fungal and bacterial attack.

Basic Density of the wood

In Table 3.17, wood basic density for the samples placed in the anaerobic environment, are shown for the 12 month period. The same system utilised for the two previous sites, has been adopted.

These values are generally below or in line with the expected average (compared to those indicated in the literature (see page 12).

Wood	BD Row 1	BD Row 2
Oak	0.57	
Oak		0.59
Oak		0.53
Oak		0.64
Oak	0.57	
Wood	BD Row 1	BD Row 2
Pine		0.35
Pine	0.37	
Pine	0.40	
Pine	0.36	
Pine		0.35

Table 3.17.

Chapter 4

4.1 Conclusions

4.1.1 Vrouw Maria

The analyses of samples placed in the aerobic environment at the Vrouw Maria wreck site show a progress in degradation. Significant changes to the wood structure have been detected within the two intervals considered in the MoSS Project (3 and 12 months). Very little sedimentation is present on the wood surface, with fine sediment, small bivalves and algae being recorded. All x-rayed samples show no evidence of woodborer attack, with a point-rating scheme, of grade 1, with 0% surface destruction. Scanning Electron Microscopy showed the presence of fungal hyphae after 3 months. Also, the presence of bacteria was found at a superficial level, though bacteria have not penetrated the wood cells. After 12 months, all samples showed evidence of degrading bacteria and fungi. Bacteria have penetrated the cell walls and significant changes have occurred at a structural level close to the sample surfaces. Wood structure has been damaged by this activity. The presence of fungi was confirmed by the analyses carried out with the dissecting microscope, where several different species were identified.

The moisture contents calculated for the samples placed in Finland, show an increasing trend, indicating increases in permeability. Wood density values also suggest low levels of wood degradation. These values vary depending on the grade of the geotextile the samples were wrapped in.

Samples placed in the anaerobic environment show a relatively high presence and level of attack by bacteria, on both oak and pine samples. It should be noted however,

that these wood blocks were not inserted vertically down to 50 cm. beneath the sediment, as for the two other sites, but horizontally just below the sediment, due to the difficulties of the procedure on the site.

4.1.2 Darsser Kogge

Samples placed in the aerobic environment around the Darsser Kogge show an increased level of degradation. A difference in level of sedimentation was evident among the various samples. As expected, the higher the grade of the geotextile, the lower the level of sedimentation. On the 12 month period control samples, when the sediment had been washed away, small holes from initial wood-borer attack were visible to the naked eye. Terram covered samples however, showed no obvious signs of surface attack. By examining the x-rays for the 5 month period samples, it was confirmed that no woodborer infestation has occurred. Occasionally, small white dots were visible (Pine Control and Terram 500 covered samples).

Samples left on site for 12 months, again showed the presence of small white dots on the x-ray images. Interpretation is unclear but these may represent initial borer infestation. In fact, one control sample showed a larger shadow confirmed as initial attack by shipworm, by the later microscope examination. The analysis at the Scanning Electron Microscopy for the 5 month samples, revealed wood degradation within pits on pine samples which is quite advanced, whereas on oak samples fungal attack is evident but the overall cell structure remains intact. Wood degradation is quite extensive on samples after 12 months on site. Fungal and bacterial degradation is evident in both pine and oak samples and it is interesting to note that the different geotextile grades had little

influence on the degree of degradation, all samples showing a similar degree of attack.

Initial degradation by woodborers is present on almost all samples. From the controls to those wrapped in geotextile grade 4000, some level of attack was revealed using the dissecting microscope. This contrasts with the radiographs, which didn't show any attack, unless the small white dots are interpreted as initial infestation. Quite often the x-ray analysis did not detect the infestation because the attack was at a very early stage. Small holes caused by borers were clearly visible under the microscope however, as were shell residuals or pallets useful for the identification of the species. The moisture content calculated for the samples placed in Germany, showed a slightly increasing trend, indicating increases in permeability from degradation. Reductions in wood density reflect the same trend. These values vary depending on the grade of the geotextile the samples were wrapped in.

Samples placed in the anaerobic environment show a distinctive degradation pattern by bacteria, on both oak and pine samples.

4.1.3 Burgzand Noord 10

The difference in the level of sedimentation between samples wrapped in different geotextile grades, for the different intervals on site is very dramatic. All control samples have been thoroughly covered by barnacles, bivalves and algae. Some degradation is visible, as is the very initial stages of infestation by woodborers, after just 3 months on site. The change in the 12 month period is very clear from the X-rays of samples, which show severe attack by woodborers, especially on control samples. This was confirmed by studies at the microscope. The

combined findings of x-rays and microscopic investigation, show clear stages going from initial infestation to severe attack.

Overall, the wood structure shows evidence of wood degradation at a superficial level as revealed by SEM studies at high magnification. This degradation is quite extensive in the 12 month period samples.

The dissecting microscope has allowed detection of different stages of infestation and attack by woodborers, from the very early phases to severe degradation. Specimens have been collected, analysed and compared to keys. Species identified are of *Teredo navalis*.

The moisture content calculated for the samples placed in The Netherlands, shows an increasing trend again indicating increasing in permeability. Wood density reflects the same trend. These values vary depending on the grade of the geotextile the samples were wrapped in.

Samples placed in the anaerobic environment show extensive colonisation and attack by bacteria, on both oak and pine samples.

References

- Blanchette et al. (1990). Biological degradation of wood. In: Archaeological wood. Properties, chemistry and preservation, Advances in Chemistry Series 225, (Eds: R.M. Rowell and R.J. Barbour), American Chemical Society, Washington D.C., 141-174.
- British Standards Institution, Wood preservatives – Determination of the protective effectiveness against marine borers. BS EN, 275:1992.
- Building Research Establishment, "A handbook of softwoods", 1977.
- Building Research Establishment, "A handbook of softwoods", 1972.
- DCMS, (2004). "Protecting our Marine Historic Environment: Making the system work better".

Hedges J.I., 1990. The chemistry of archaeological wood. In: Archaeological Wood. Properties, Chemistry and Preservation. Ed. Rowell R.M. & Barbour R.J. American Chemical Society.

Hyde, K.D., and Pointing S.B., 2003. Marine Mycology. A practical approach. Fungal Diversity Press.

Kohlmeyer, J. and Kohlmeyer, E., (1979). Marine mycology: the higher fungi, Academic Press, New York.

Kollmann F.F.P., Côté W.A., (1968). Principles of wood science and technology I. Solid Wood. Springer-Verlag.

Oxley, I., (1998). "The environment of historic shipwreck sites: a review of the preservation of materials, site formation and site environmental assessment". Master of Sciences thesis, University of St Andrews.

Poumou, A., (1999). In situ protection and conservation of the Zakynthos wreck. PhD Thesis at Portsmouth University.

Appendix 1

Tensile Testing of Buried Cotton samples – Paul Wyeth¹

Specimens

Strips of buried cotton fabric were supplied together with a sample of untreated cotton cloth:

Germany (4 bars) – G1 (2 fragments), G2 (3 fragments), G3 (4 fragments), G4 (4 fragments)

Holland (3 months) – 2 long strips and 2 small fragments

Methodology

The specimens were inspected and photographed before samples were removed for testing.

10 cm long strips of 10 or 20 mm width were cut from the specimens (Image: Samples). The sampling locations are indicated on the accompanying images (G1-4,H). Care was taken to cut parallel to the direction of the weave so that the edges were even.

Similar samples were cut from the standard cotton reference fabric. In addition 10 and 20 mm width strips with frayed edges were prepared to avoid edge artefacts and to compare with the straight edge cut reference samples. Samples were equilibrated under controlled conditions (22 ± 2 °C, RH 53 ± 2 %).

Two strips of the reference cotton were soaked in brine (35 ppm NaCl) for 24 h, gently pressed to remove excess fluid and then air dried.

All the prepared samples were subjected to tensile testing using an Instron instrument. A 5 kN load cell was used for all the reference samples and the 20 mm width buried cotton samples; the test was carried out at an extension rate of 10 mm/min. A 100 N load cell was used for the 10 mm buried cotton samples; such

tests were carried out at an extension rate of just 5 mm/min. The temperature and humidity were ambient. The strips were secured in serrated-faced mechanical grips for the tests. There was no pull-out and, while in some tests breakage occurred close to the grips, the results were sufficiently consistent that none were discarded.

Specimen characteristics

The specimens from Germany appear the more deteriorated on visual inspection and were provided as numerous fragments, indicative of their relative weakness; the edges of the specimens are fragile and generally uneven. Some, eg. G3, show an orange brown colouration. Those from Holland appear less discoloured and more robust and show evidence of the original cut edges.

All the samples had a coarse handle, though those from Holland retained more flexibility. [Since it was thought that simple immersion in sea water and subsequent drying and inclusion of salt within the fibres and the weave might produce a stiffened fabric, reference samples soaked in brine and then air dried were prepared for comparative testing.]

Tensile test results

As there was extraneous material, such as sand, adhering to the buried cotton specimens, and, presumably, included salt, the samples were not weighed. Rather the results (breaking load and modulus) were normalised to refer to the properties per unit width of material.

8 reference samples were tested. There was no significant dependence of the normalised breaking load nor extensibility on the test strip width (10 or 20 mm). Carefully cut straight edges were also found to give as consistent results as samples with

¹ Textile Conservation Centre, Winchester Campus, University of Southampton.

frayed edges.

The stress versus strain curves for the reference cotton appear well behaved (eg. Fig 1). The analogous curves for the Holland samples were also readily interpretable (eg. Fig 2), however, those for the German samples generally showed non-ideal behaviour (eg. Fig 3). Consequently accurate extensibility data could not be extracted for the latter samples.

The average values for the tensile properties of the reference cotton fabric (8 test samples) are given in the table together with the results for the brine treated reference (2 test samples) and the buried cotton samples.

Discussion

The buried samples are quite variable in appearance and apparent state of degradation, even within a single specimen. The mechanical data probably represents the optimum for that particular specimen since the sounder regions were sampled and the severely degraded edges were avoided.

Soaking cotton in brine and drying does not alone compromise the tensile strength, in the short term, and may even enhance the extensibility, though the latter could relate to an increased moisture content if these samples were not fully equilibrated.

The tensile properties of the buried samples span a range, reflecting the variable rate of deterioration along and across each strip.

The samples from Germany are quite weak with residual strengths just 1.3 – 11.0 % of the original. The tops of the strips (G3b, G4a) may be somewhat more degraded than the bottoms (G3a, G4b).

The Holland samples are the less degraded. Under a quarter residual strength remains at the top and bottom of the strip tested, though within the strip the residual strength

sample	width / mm	Breaking load / N/mm	Extension at break	Modulus / N/mm	Residual strength %	Residual extensibility %	Residual modulus %
Ref.		18.8 (1.0)	0.135 (0.006)	142 (11)	100	100	100
Ref. Brine	20	18.7 (18.5-18.9)	0.174 (0.171-0.177)	108 (104-111)	99.3	129	75.7
G1a	20	1.24	<0.10	-	6.6	-	-
G1b	20	0.32	<0.05	-	1.7	-	-
G2	10	0.84	<0.02	-	4.5	-	-
G3a	10	2.06	<0.08	-	11.0	-	-
G3b	10	0.68	<0.13	-	3.6	-	-
G4a	20	0.25	<0.05	-	1.3	-	-
G4b	10	1.53	<0.10	-	8.1	-	-
Ha	10	4.44	0.070	63.4	23.6	51.9	44.6
Hb	20	3.16	0.119	26.6	16.8	88.1	18.7
Hc	20	9.92	0.092	108	52.8	68.1	75.9

Standard errors are shown in parentheses for reference cotton and the range for the brine treated reference cotton.

rises above 50%. There is a complementary reduction in modulus for each sample.

Conclusions

Significant deterioration of cotton has occurred in all cases. The specimens from Holland are less degraded than those from Germany.

Images of the specimens



G1

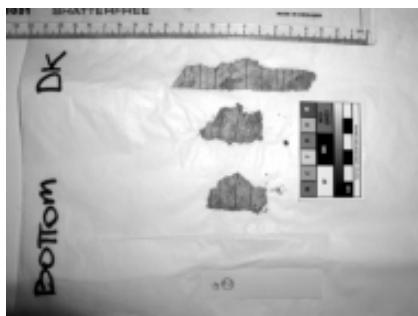

G2



G3



G4



H

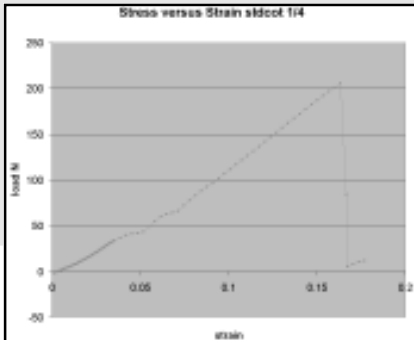

Fig 1. Stress versus strain curve for reference cotton sample.

Tensile Testing of Buried Cotton samples from Finland

Specimens

Strips of buried cotton fabric were supplied attached to six Perspex bars with plastic ties. "Finland 12 months" was inscribed on three of the bars.

Methodology

The specimens were allowed to dry in a fume cupboard for 48 hours. Sampling and tensile testing (gauge lengths 50-80 mm, 100 N load cell) was then carried out as before. Since the bars were not differentiated the sampling locations were not distinguished.

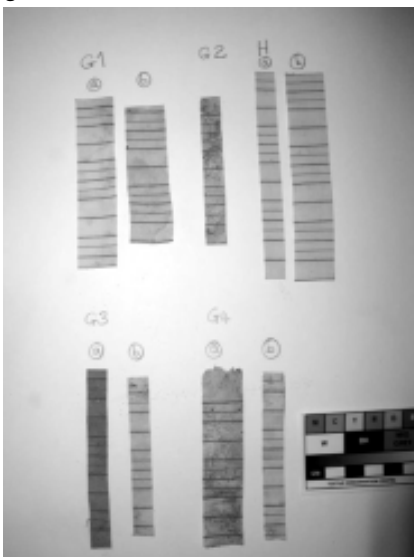

Prepared samples.

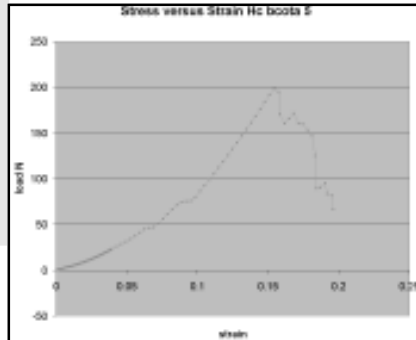

Fig 2. Stress versus strain curve for sample Hc.

Specimen characteristics

The specimens were wet and carried a high stench of decomposition; there was adhering mud and in places the cotton itself was a mottled orange. Much of the cotton seemed to have been lost through extreme degradation (Figure on next page); strips (40-50 cm) on one side of four Perspex bars remained reasonably intact, and 9 samples were cut from these for testing. Visually, the intact strips did not appear to have suffered more extensive damage at the edges, but were evenly deteriorated across their widths.

Tensile test results

The results (breaking load and modulus) were again normalised to refer to the properties per unit width

sample	width / mm	Breaking load / N/mm	Extension at break	Modulus / N/mm	Residual strength %	Residual extensibility %	Residual modulus %
Ref.		18.8 (1.0)	0.135 (0.006)	142 (11)	100	100	100
Ref. Brine	20	18.7 (18.5-18.9)	0.174 (0.171-0.177)	108 (104-111)	99.3	129	75.7
1	10	1.89	0.05	37.8	10.0	37.1	26.6
2	10	6.85	0.09	76.1	36.4	66.7	53.6
3	10	1.71	0.055	31.1	9.1	40.8	21.9
4	10	2.70	0.05	54	14.3	37.1	38.0
5	10	1.32	0.075	17.6	7.0	55.6	12.4
6	20	2.55	0.08	31.8	13.5	59.3	22.4
7	20	2.64	-	-	14.0	-	-
8	10	5.55	0.05	111	29.5	37.1	78.1
9	10	5.23	0.05	104.6	27.8	37.1	73.6

Standard errors are shown in parentheses for reference cotton and the range for the brine treated reference cotton.

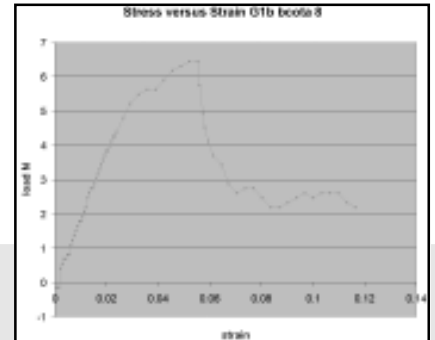

Fig 3. Stress versus strain curve for sample G1b.

of material, and were compared to the reference data collected previously. The stress versus strain curves were reasonably well behaved, allowing an estimate of extensibility as well as breaking load for 8 samples (table below).

Discussion

The buried Finland samples show wide ranging variability. A significant proportion of the cotton strips appeared to have been lost through deterioration. The remaining material was whole in large part. The samples tested, representing the sounder material, showed a range of behaviour, with residual strength: 7.0 – 36.4 % [residual extensibility: 37 – 67 %; residual modulus: 12 – 78 %].

Conclusions

Significant deterioration of cotton has occurred.

The Finland samples tested seem to have residual strengths between those of the German and Holland samples previously assessed. However, it should be noted that a significant fraction of the Finland cotton appears to have undergone extreme degradation, such that it has been lost completely.

Appendix 2

Nuclear Magnetic resonance

The chemistry of waterlogged wood varies under the influence of burial conditions such as water chemistry and presence of degrading organisms. NMR is an extensive method for the chemical analysis of the wood providing detailed analyses of the major carbon forms that can be linked to different lignin components. This technique provides information about the loss of wood components as well as the chemical transformation of the residual components (Hedges, 1990). From the original sample, a section of wood of roughly 7.5 x 3 x 2.5 cm was cut away and oven-dried at a temperature of 50°C. It is then cut into small fragments and subsequently milled and sieved.

This is a very expensive test and the preparation of each sample has to be carefully carried out to avoid contamination from different components.

Within the MoSS project this analysis has been done only partially because of lack of funds. Therefore the results obtained cannot be interpreted.



Image of the specimens from Finland.

Appendix 3

The Physical and Chemical Measurements at the Vrouw Maria Wreck Site from 12th September 2002 to 26th August 2003

By Riikka Hietala, Tero Purokoski, Hannu Vuori, Tuomo Roine, Juhani Rapo, and Juha Flinkman¹

An SBE16plus SEACAT recorder and a 300 kHz WH-ADCP current profiler from RD Instruments were installed near the wreck of Vrouw Maria to record the physical and chemical properties of the water at the bottom. Both the data loggers have worked well and we now have data from a period of almost a year. The data gives us a thorough picture about the annual changes of the near-bottom water mass and even some information about the processes that cause the changes too. This report gives a summary about the results so far.

1. Data loggers and measurement period

In September 2002, an SBE16plus SEACAT recorder was placed on the sea bottom near the wreck of Vrouw Maria to record the physical and chemical properties of the near-bottom water. The recording interval was 1 - 2 hours. Also a 300 kHz WH-ADCP (Acoustic Doppler Current Profiler) from RD Instruments was installed to measure the current velocities between the bottom and near-surface area. In addition to these, two Seamon temperature recorders were set to collect comparison material. Picture 1 shows a diagram that illustrates how the data loggers were placed.

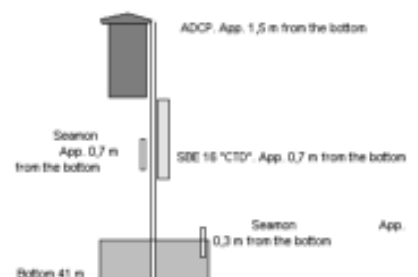

Picture 1. A diagram of the data loggers' placement.

¹ The Finnish Institute of Marine Research

The SBE16plus SEACAT recorder has the following sensors:

- temperature
- conductivity
- oxygen
- pH
- oxygen reduction potential
- optical backscatter

Water salinity can be calculated from conductivity and temperature.

The accuracy of the conductivity and temperature sensors was estimated by comparing the calculated salinity to the measured salinity of a water sample.

The estimated accuracy of the salinity is better than $\pm 0,02$ ‰.

The estimated accuracy of the temperature sensor is better than $\pm 0,02$ °C.

(Also Seamon Mini recorders were used in temperature comparison.)

The accuracy of the rest of the sensors was not evaluated. The data from the oxygen reduction potential sensor and the pH sensor appear realistic even if the oxygen reduction potential sensor seems to react too slowly on sudden changes. The strong increase of the optical backscatterance before the cleaning of the instrument at the end of May is most likely due to bio-fouling of the sensor.

The profiling range of the WH-ADCP is between 4,5 – 36 meters from the bottom, which means that the uppermost data is from 4 meters below the surface. The standard deviation of the measured current velocity is according to the manufacturer 1,8 cm/s on the settings used.

Data from the SEACAT was downloaded in mid-December and the one-hour logging interval was changed to two-hour interval. The interruption in recording lasted for less than twenty-

four hours. The SEACAT was raised at the end of May 2003 for a couple of weeks so that the instrument could be cleaned and the data downloaded. At the end of August 2003, all the data loggers were raised for cleaning and data downloading. The loggers were then again re-mounted on the bottom. It is planned that the next cleaning and data processing is done in May 2004. We now have processed data from a period of almost a year. Divers mount and raise the loggers. No surface buoys are thus needed. As a result, ice cannot put the loggers in danger and the instruments can stay in the sea all round the year.

Besides the data from the loggers, we used the following information when interpreting the results: temperature data from the Utö fixed hydrographic station of the Finnish Institute of Marine Research, wind data from the Utö weather station of the Finnish Meteorological Institute, and the temperature data from the depth of app. 2 meters from the Degerby tide gauge of the Finnish Institute of Marine Research. Utö is located app. 25 kilometres to the

west and Degerby app. 85 kilometres to the northwest from Vrouw Maria.

2. Temperature, salinity, oxygen and current velocities in different times of the year

The temperature, salinity and oxygen throughout the year are shown in picture 2.

The rest of the data from the SEACAT (Redox, pH and backscatterance) are shown in picture 3.

Surface and bottom velocities and wind speed at Utö are shown in picture 4.

The salinity and temperature remained stable in the early autumn of 2002. The oxygen level decreased continuously. The temperature was app. 5,3 ° C and the salinity 6,5 ‰. The water stratification was so strong that the oxygen-rich water from the surface did not mix with the near-bottom water, and thus the decomposition of sinking material used all the oxygen at the bottom. The bottom velocity was very weak: 3 cm/s on average.

On the 23rd of October the properties

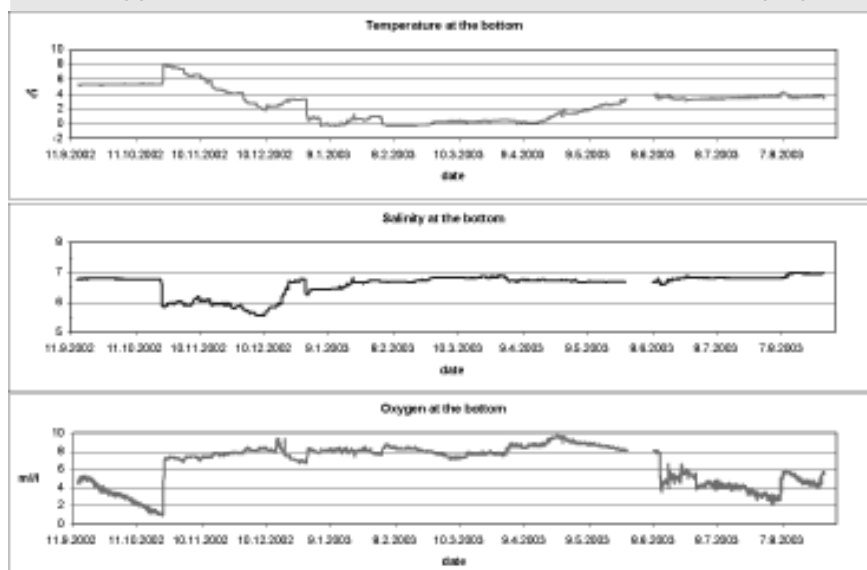

Picture 2. Temperature, salinity and oxygen at the wreck site of Vrouw Maria from 13th September 2002 to 26th August 2003.

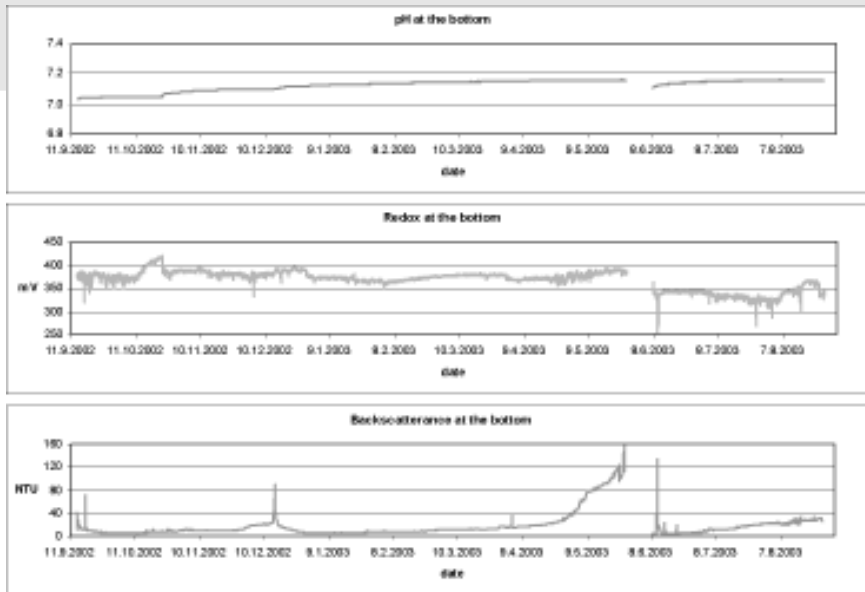

Picture No 3. pH, Redox and backscatterance at the bottom near Vrouw Maria from 13th September 2002 to 26th August 2003.

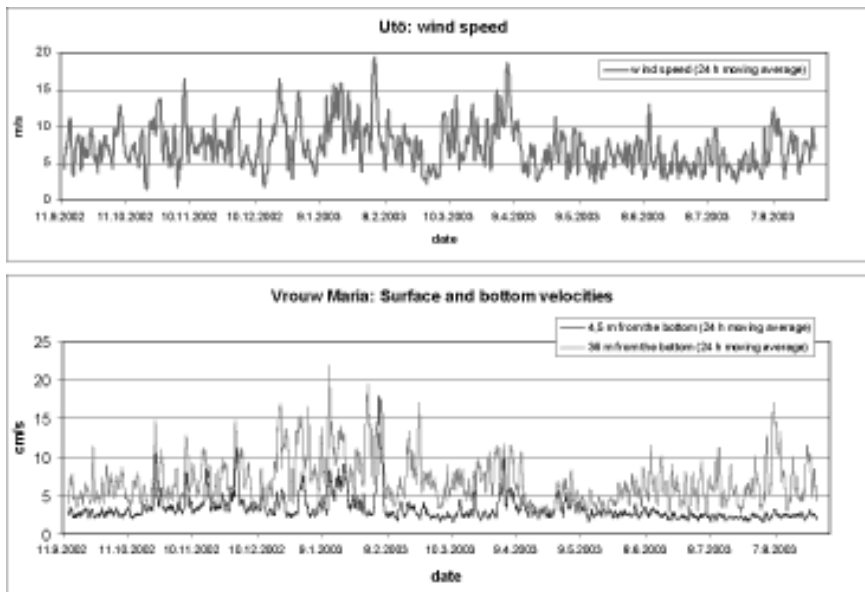

Picture 4. Wind speed at Utö and the surface and bottom current velocities near Vrouw Maria from 13th September 2002 to 26th August 2003.

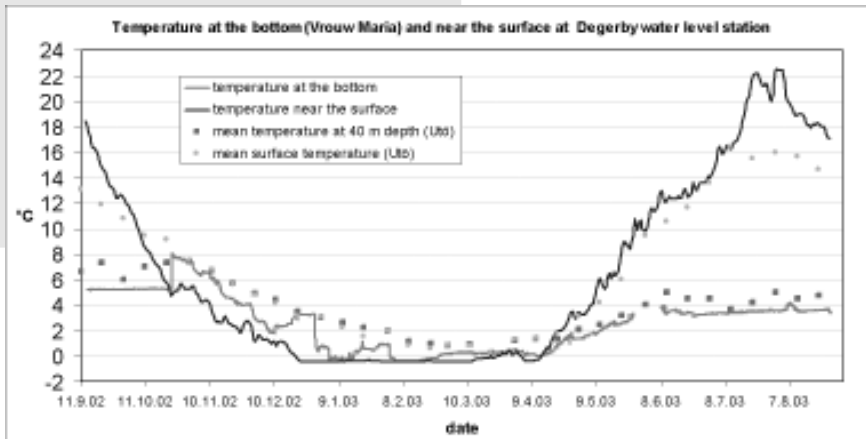

Picture 5. Temperature at the bottom (Vrouw Maria) and near the surface at Degerby water level station from 13th September 2002 to 26th August 2003 and long term mean temperature at 40 meters and surface (Utö).

of the near-bottom water mass suddenly changed. The temperature increased nearly 3 degrees, the salinity decreased app. 0,9 ‰ and the oxygen level increased significantly (1 ml/l ? 7,5 ml/l). Also the values of other SEACAT measured parameters changed. However, the oxygen reduction potential sensor seems to have reacted too slowly on the rapid change. On that day also the current velocities in the entire water column were considerably high: the 24-hour average near the surface was app. 15 cm/s. The maximum speed was 25 cm/s. At the bottom the 24-hour average was app. 10 cm/s with the maximum of 17 cm/s.

After the 23rd of October the water column stratification broke down. The water was mixed from the surface to the bottom and therefore greater variations could be noticed also near the bottom. The mean current velocity near the bottom doubled. When compared with the surface temperature at the Degerby tide gauge, it can be seen that up till mid-December the temperature at Vrouw Maria decreased almost at the same pace as at Degerby (see picture No. 5.). New, saltier water mass arrived at the bottom after mid-December and the

water column stratification was weak. At the end of December the temperature at Vrouw Maria fell close to zero and at the beginning of January it was the same as that at Degerby, very near the freezing point. According to the Ice Service of the Finnish Institute of Marine Research (Patrick Eriksson, personal communication), there was ice on the area from the beginning of January to the end of March. The ice type varied from level ice to open drift ice. All through the period (January – March) the near-bottom temperature remained very low. The ice affected the measured velocity values; there were false peak values that did not normally appear.

In mid-April the temperature stratification started to develop and the near-bottom temperature increased slowly till the end of May. During the summer there were only small variations in temperature and salinity, but the oxygen level at the bottom decreased almost continuously. Also the bottom current velocity was very weak from the beginning of June on. New, more oxygen-rich and saltier water arrived at the beginning of August. At the same time there was a moderate northern wind and also current velocity at the surface reached its

summertime maximum. The surface velocities are typically affected by wind.

3. Summary of the conditions at bottom

The range of temperature was less than 10 °C. In the winter time the minimum was –0,4 °C which is very near the freezing point. The water was at its warmest in the late autumn (8,1 °C) when the whole water mass was mixed from the surface to the bottom. In the summer there were practically no changes in the temperature.

The salinity varied roughly one unit; it was 5,5 – 6,6 ‰. The variation in salinity, as well as in temperature, was greatest in the autumn.

The variation in oxygen was clearly affected by the variations in the water column stratification. In winter and spring, when the stratification was weak, the oxygen level at the bottom was high. In times of strong stratification, sinking material used oxygen and thus the oxygen level decreased continuously. It was only the arrival of new and more oxygen-rich and saltier water mass that improved the oxygen level in summer. The average, minimum, maximum, and standard deviation of the SEACAT measured parameters are shown in Table 1.

The currents at the bottom were on average very weak. The recorded values are close to the limit of measurement accuracy. Picture No. 6 shows the distribution of the bottom current directions in different speed classes. In the currents of the speed class 4 – 8 cm/s the effect of bottom topography can be seen clearly: currents parallel to the main axis are more common than currents perpendicular to the main axis. Currents more than 8 cm/s are solely parallel to the main axis.

Currents less than 4 cm/s were dominant (72% of the time) and currents more than 8 cm/s occurred only for 5 % of the time. The average current speed during the time of strong stratification (summer and early autumn) was app. 2,5 cm/s and at other times (winter and spring) app. 4 cm/s. Table No. 2 shows the average, maximum, minimum, and the standard deviation of both near-bottom and near-surface current velocities in different stages of water column stratification.

The measurements at Vrouw Maria from a period of a year show that in the water column above Vrouw Maria the stratification is weak from late autumn to spring. During this time the near-bottom water mass interacted with the water of the top layers. In early autumn and summer the thermocline separates the near-bottom area, where the salinity and temperature were practically stable and current velocity low. Significant changes were to be seen only in the oxygen: the level of oxygen decreased towards autumn.

The recordings at Vrouw Maria correspond to the picture we have on the annual stratification development of the Archipelago Sea. The long-term mean temperatures from different depths at the Utö hydrographical station describe well the typical annual development (see picture No. 5., the surface and the depth of 40 meters according to Alenius & Haapala 1994). Also other statistics of salinity and temperature from the Archipelago Sea show that the vertical mixing nearly reaches the bottom (Alenius & Haapala 1994). In the late autumn of 2002 the temperature was a couple of degrees lower than on average both at Vrouw Maria and the Degerby tide gauge (see picture No. 5). Observations on

	Temperature [°C]	Oxygen [ml/l]	Backscatterance (D + A) [NTU]	pH	Oxidation Reduction Potential [mV]	Salinity [PSU]
average	3,22	6,10	15,79	7,12	365,12	6,57
minimum	-0,38	0,85	2,81	7,03	253,46	5,54
maximum	8,07	9,77	158,54	7,16	420,76	7,00
standard deviation	0,17	1,08	8,86	0,01	12,23	0,08

Table 1. The average, minimum, maximum, and standard deviation of SEACAT measured parameters.

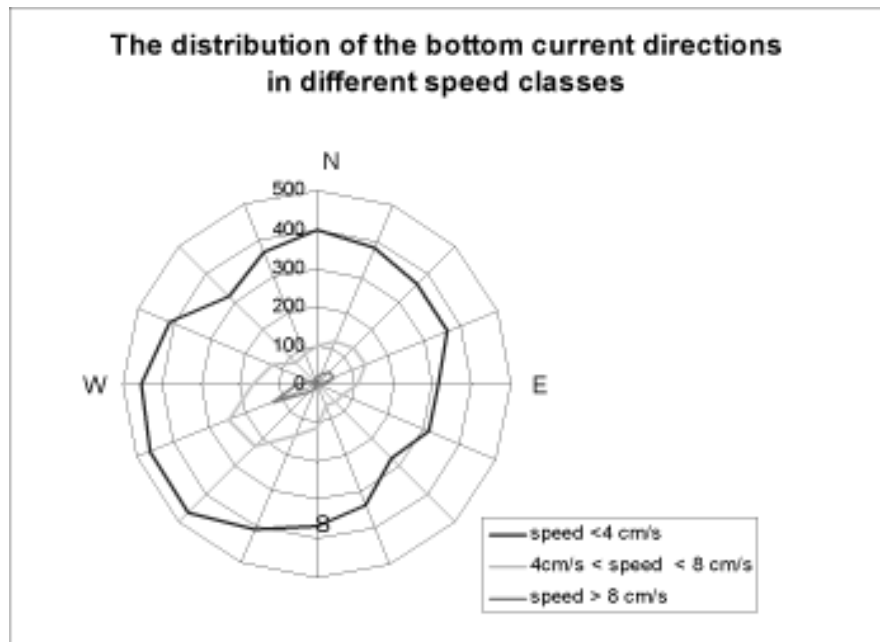

Picture 6. The distribution of the bottom current directions in different speed classes. The unit used is the number of recordings (one-hour averages). The current direction shows the direction to which water moves.

cm/s	whole period		winter-spring		summer - early autumn	
	near the bottom	near the surface	near the bottom	near the surface	near the bottom	near the surface
Average	3	7	4	7	2	6
Maximum	23	39	23	39	8	28
Standard deviation	2	5	3	5	1	4

Table 2. The average, maximum, minimum, and the standard deviation of current speed during different stages of water column stratification.

other sea areas surrounding Finland also show that the surface temperature in the late autumn of 2002 was a couple of degrees lower than on average.

In conclusion it can be said that the frequent measurements of chemical and physical parameters near the sea bottom together with the current profiling give us interesting infor-

mation about the seasonal changes and the exchange and mixing of water.

References:

Alenius, P. & Haapala, J. 1994: Temperature and salinity statistics for the northern Baltic Sea 1961-1990.- Finnish Mar. Res. 262:51-121.

Appendix 4

Drilling resistance measurements - a fast method for the examination of waterlogged archaeological wood by Prof. Dr. C. von Laar ¹

Needle drill resistance measurements are a proven method for the detection of decay and insect damage as well as growth ring structures in wood and also in wood constructions. The method is practically used since 1988 for tree and timber inspection (Brandt and Rinn 1989).

Already 1996 archaeological waterlogged woods were examined at the York Archaeological Wood Center (UK) with a drill resistance device. At this a Sibert Decay Detecting drill (version DDD 200) was used whose measurement dissolving however was relatively low (Panter 1996).

Examinations within the 2002 and 2003 at the Darss cog were carried out with a high-resolution, electronic regulated RESISTOGRAPH 3450-P of Rinntech, covering a drilling piece, a battery pack with printer, power supply and an internal data logger. The RESISTOGRAPH drives a drilling needle under fast rotation into the wood. The mechanical penetration resistance profile of the needle is measured, stored and printed versus drilling depth. Decay lowers the drill resistance characteristically and can be identified by depressions in the profiles. The measured profiles highly correlate to the gross density (Rinn et. al. 1996; G. Chantre, P. Rozenberg 1997; Fikret Isik and Bailian Li 2003). This method is suitable for the examination of archaeological woods particularly with greater dimensions at which the remaining drill holes of only 3 mm can be neglected. The single measuring depending on thickness of the object lasts approximately for a minute and can be immediately interpreted about a

printed drilling profile.

Decomposed/decayed wood substance in archaeological water woods frequently shows no more measurable drilling resistance. Largely intact wood can however be described to the year ring structure depending on drilling direction and by the height of the drilling resistance. The bore holes of the ship worm *Teredo navalis* are recognizable in the drilling profile with sharp losses which often suffice up to the area of the baseline. One drilling hole has to be assigned by to one single profile loss usually (von Laar 2003).

The starboard knee of the Darss cog examined already 2002 with a few drillings was held and checked for further damages 2003 once more. The externally visible damages were low the wood substance partly superficially smoothed and between 0.5 and 2.5 cm decomposed. 35 measurements altogether were carried out above and by the side of the object. At four drillings bore holes of the ship worm *Teredo navalis* were attested. No heavy new attack of the to starboard knee has therefore been made by the ship worm since 2002. Although the used machine was not calibrated specifically, the proven correlation to wood density allows relative comparison within and between profiles measured. The average relative drill resistance was mostly around 400. This refers to a beginning wood decay as is to be expected for 700 year old waterlogged wood. At some drillings a piece of recent oak was put in front of the starboard knee and drilled through, clearly visualising the beginning of decayed parts of the historic oak by comparison.

A detailed report about the examinations is planned at a later date.

Brandt, M., Rinn, F. 1989: Der Blick in's Innere von Bäumen. Eine Übersicht über Verfahren zur Stammfäule-diagnose. Holz Zentralblatt Nr. 80, 5.7.1989, S. 1268 und 1270.

Rinn, F., Schweingruber F.-H., Schär, E. 1996:

RESISTOGRAPH and X-Ray Density Charts of Wood. Comparative Evaluation of Drill resistance Profiles and X-Ray Density Charts of Different Wood Species. HOLZFORSCHUNG Vol. 50 (1996) pp. 303-311.

Panter 1996:

Ian Panter, Jim Spriggs: Condition assessments and conservation strategies for waterlogged wood assemblages. Proceedings of the 6th ICOM Group on Wet Organic Archaeological Materials Conference, York 1996, 185 - 200

Von Laar 2003:

Claudia von Laar: Zustandsuntersuchungen an archaischen Nasshölzern mit der Bohrwiderstandsmethode. Beiträge zur Erhaltung von Kunst und Kulturgut, Verband der Restauratoren, 1, 2003, 85 - 93

G. Chantre P. Rozenberg 1997:

Can drill resistance profiles (Resistograph) lead to within-profile and within-ring density parameters in Douglas-fir wood? In: Proceedings of CTIA - International Union of Forestry Research Organizations (IUFRO) International wood quality workshop: Timber Management Toward Wood Quality and End-Product Value, Québec, Qué. 18.-22. Aug. 1997. Edited by R. Zhang, R. Gosselin, and G. Chauret, ForintekCanada Corp., Sainte-Foy, Qué, pp. 41-47.

Fikret Isik and Bailian Li 2003:

Rapid assessment of wood density of live trees using the Resistograph for selection in tree improvement programs. Can. J. For. res. 33: 2426-2435.

¹ University of Technology, Business and Design, Department of Civil Engineering, Philipp-Müller-Straße, Postfach 1210, 23952 Wismar



David Gregory

Monitoring Wooden Shipwrecks: Monitoring The Burgzand Noord 10 and Darss Cog using the EauxSys data logger

Table of Contents

1. Introduction	39
2. The rationale for monitoring water quality parameters and sediment conditions	39
3. Parameters to monitor in open water.	39
3.1 Sediment Transport	39
3.1.1 Turbidity	39
3.1.2 Sediment Layer Device	40
3.2 Temperature, Salinity, Dissolved Oxygen	40
4. Parameters to monitor within sediment	40
4.1 Redox Potential (Eh) and Acidity / Basicity (pH)	40
5. The Eauxsys Datalogger	41
6. Results	41
7. Summary of Results	45
7.1 The Darss Cog	45
7.1.1 Parameters in open water	45
7.1.1.1 Temperature	45
7.1.1.2 Depth	45
7.1.1.3 Salinity	45
7.1.1.4 Dissolved oxygen content	45
7.1.1.5 Turbidity & Sedimentation Device	45
7.1.2 Parameters within sediment	46
7.1.2.1 pH	46
7.1.2.2 Redox	46
7.2 The BZN 10	46
7.2.1 Parameters in open water	46
7.2.1.1 Temperature	46
7.2.1.2 Depth	46
7.2.1.3 Salinity	46
7.2.1.4 Dissolved oxygen content	46
7.2.1.5 Turbidity and Sediment Level	46
7.2.2 Parameters within sediment	47
7.2.2.1 pH	47
7.2.2.2 Redox	47
8. Discussion and implications of Results	47
8.1 Open Water Parameters	47
8.1.1 Salinity, Temperature, Dissolved oxygen	47
8.1.2 Turbidity & Sediment Level	47
8.1.3 Sediment characteristics	47
9. Conclusions and recommendations	48

1. Introduction

When a wooden ship sinks, it may come to rest on or in the seabed. The marine environment in many instances is very dynamic and physical processes, such as scour and sediment movement, around shipwreck sites are potentially the most damaging threat as they can destabilise a site leading to the rapid loss of archaeological material. If a shipwreck is not in immediate danger of being “washed away” by currents and tides, it will be progressively colonised by a variety of biological organisms. This is initiated by the attachment of bacteria to the surface, followed by other microorganisms including diatoms, fungi, micro algae, protozoa and boring crustacea and mollusca. Bacteria and fungi produce extra cellular enzymes, which destroy the material on which they grow, while the crustaceans and mollusca bore into the wood, which they ingest and may subsequently utilise. Additionally there are fouling organisms such as algae, polysoa, tunicata and mollusca, which use the wood as a substrate to grow upon.

By far the most damaging of these organisms are the marine wood-borers, which may cause damage and loss of archaeological information to exposed shipwrecks in a relatively short period. The major factors influencing the colonisation by marine borers are temperature, salinity, depth and the dissolved oxygen content of the water. The “determining” factors for colonisation by marine borers are the dissolved oxygen content and salinity; if there is little or no oxygen or salt present, they cannot respire and survive. After the marine borers, fungi and bacteria are the next agents of deterioration to consider. These microorganisms have a relatively minor part to play in the total breakdown of wood in seawater but their activity will affect its long-term

preservation within sediments.

2. The rationale for monitoring water quality parameters and sediment conditions

As can be seen the environment has to be considered in two parts. First, open seawater whereby sediment movement and the activity of wood-borers may be the main threat. It was known that the environmental conditions around the BZN10 and Darrser cog sites, which were buried within sandy sediments, were particularly dynamic and sediment movements could lead to the exposure of these sites, thus methods to monitor sediment movement were to be investigated. Similarly, both were exposed to the threat of wood borer activity.

Second, within sediments where the main threat is from bacteria and fungi. The rationale for using wood blocks and cellulosic material has been discussed elsewhere in this report. This section of the report discusses the rationale for measuring the water quality parameters in open water and conditions within sediments and selection and development of equipment. Information needed to be collected (Logged) continually during the period of the project in order to determine changes in the environment due to local and seasonal effects. Data loggers for these purposes are commonly used within the oceanographic industry to measure water quality parameters yet there is no such equipment available, to the best of the author’s knowledge, which can monitor both parameters in open seawater and within sediments. From the coordinator of the monitoring programmes previous experience with the British data logger manufacturer EauxSys UK, it was decided to develop their existing range of technology (Water Watch System 2680) to monitor the wrecks

of the BZN10 and the Darss Cog. After discussion with the Maritime Museum of Finland, a different logger was selected for the site of the Vrouw Maria. The site of the Vrouw Maria is significantly different to the other sites being much deeper, colder, with little sediment coverage and /or movement and with problems of accessibility (for many months of the year it is impossible to gain access to the site due to ice). One of the main concerns was that the battery life of the EauxSys system would not last for the long periods the logger would be deployed on site due to the extremely cold water. In discussions with the Finnish Institute of Marine Research it transpired that the Maritime Museum could have access to SeaBird datalogger and other monitoring equipment which had been tried and tested in such conditions by the Insitute of Marine Research and could monitor the required parameters. Riikka Hakala et al discuss the results using this logger (see the environmental report). The implications of the results will be included within the discussion of this report.

3. Parameters to monitor in open water.

3.1 Sediment Transport

3.1.1 Turbidity

Turbidity refers to how clear the water is. The greater the amount of total suspended solids (TSS) in the water, the murkier it appears and the higher the measured turbidity. It provides an estimate of the muddiness or cloudiness of the water due to clay, silt, finely divided organic and inorganic matter, soluble colored organic compounds, plankton, and microscopic organisms. Thus if high turbidities are recorded we can infer that they have been caused by

movement of sediment around the site.

3.1.2 Sediment Layer Device

The measurement of the amount of sediment build up (or loss) was a trial design from EauxSys. This system used an acoustic attenuation method currently used for sludge density measurement. The system operates on the principle of the attenuation (change in strength) of an acoustic signal. An acoustic pulse is transmitted by a transducer and received by another transducer positioned 1-2 metres directly above the transmitting transducer. As sediment builds up over the transmitting transducer the acoustic signal is attenuated and this can be equated to a build up in sediment.

3.2 Temperature, Salinity, Dissolved Oxygen

The growth of wood boring organisms, in particular the Teredinids or Limnoriids which were known to be present on the sites, is dependent upon the temperature, salinity, depth and dissolved oxygen content of the water. If the temperature and salinity are not within the optimal range (see Table 1) they cannot reproduce and their boring activities are greatly reduced. All boring organisms whether mollusca (Teredinids) or crustacea (Limnoriids) require dissolved oxygen from the sea water for their respiration; without this they can obviously not survive. Table 1 shows the general range of values in which these organisms grow. By correlating data collected with these parameters the risk of attack by woodborers could be assessed. The wood blocks used to assess the different types of

Wood Borer	Temperature	Salinity	Dissolved Oxygen
Teredo	5- 30°C	9 – 35 PSU	>1 mg / Litre
Limnoria	9-26°C	15- 35 PSU	>1 mg / Litre

Table 1.

woodborer and microbial attack would serve as a control / validation of these measurements.

4. Parameters to monitor within sediment

4.1 Redox Potential (Eh) and Acidity / Basicity (pH)

Marine sediments exhibit a profile of chemical species distribution, ranging from an oxidised zone at the surface, where levels of molecular oxygen, nitrate and ferric ions are relatively high, through a transitional zone to a reduced zone where the concentration of the aforementioned ions is virtually zero and instead levels of ferrous, sulphide and ammonium ions are appreciable. These chemical changes with depth in the sediment are connected to a change in habitat conditions from aerobic to anaerobic, as shown in Figure 1.

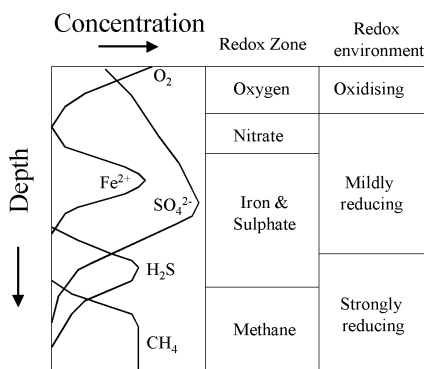

Figure 1.

Wood degrading fungi in the marine environment require molecular oxygen and levels below 0.5mg / litre have been reported to prevent their growth, thus they, like the wood boring organisms only tend to attack wood exposed to open seawater. Bacteria, unlike the marine borers

and fungi, can survive in environments with very low oxygen concentrations. The main

bacteria responsible for the deterioration of wood in waterlogged and anaerobic environments have not been formally identified and are in fact a major area of research (see the EU funded Bacpoles project <http://www.bacpoles.nl/>) thus we cannot presently say what their nutrient requirements are and thus what environments provide the optimal conditions for their growth. All we know is that they survive and degrade wood in waterlogged and anaerobic conditions. Thus, rather than measuring the individual chemical species mentioned above, information about the overall chemical processes ongoing in sediments can be determined by measuring what is termed redox potential, (Eh). This parameter gives an indication of the oxidising or reducing nature of the environment. Oxidation involves the loss of electrons while the process of reduction can be viewed as the gaining of electrons. In order to maintain electrical neutrality overall, it is clear that oxidation of one species must be accompanied by the reduction of another somewhere in the system: hence the concept of redox - the simultaneous occurrence of reduction and oxidation. In general terms the more reducing the environment is, the better it is for the preservation of wooden artefacts. The range of oxidising to reducing environments in terms of their redox potential is shown in Table 2.

Oxidising	+700 to +400 millivolts
Moderately reducing	+400 to +100 millivolts
Reducing	+100 to -100 millivolts
Strongly reducing	-100 to -300 millivolts

Table 2.

The acidity / basicity, or pH, is often measured in conjunction with redox potential as these two parameters together can aid characterisation of the natural environment and provide

a better understanding of its chemical behaviour.

5. The Eauxsys Datalogger

The configuration of the data logger was specifically developed for the MoSS project using Eauxsys' existing technology (Water Watch System 2680) and adapting it to the projects purpose (The new model was dubbed 2681). The system was based upon EauxSys' standard 6-channel submersible water quality monitoring system. The standard unit was 100mm diameter and 800mm long the electronics being contained within a stainless steel housing other parts were manufactured from black acetal copolymer. In open seawater, the system measured temperature, depth, dissolved oxygen and conductivity (which can be converted to salinity). Temperature was based on an international standard measurement parameter. Salinity was calculated from the conductivity of the seawater using the UNESCO standard equation. The Dissolved Oxygen (based on a Clarke electrode) was fitted into the logger and featured salinity compensation. The sensor was user serviceable and used a teflon membrane. The sensor was fitted with a cleaning device to remove fouling communities, which build up between measurements. Depth was measured using a pressure transducer. Turbidity was measured from the light scattered by suspended particulate material and soluble coloured compounds in the water. As with the dissolved oxygen sensor, the sensor was fitted with a cleaning device. The Sediment Layer Device was fitted to one of the

channels of the logger on a "flying lead" and positioned vertically in the sediment.

In the sediment, pH and Redox Potential were measured. The manufacturers recommended that the sensors on "flying leads" were placed inside dip wells (perforated plastic tubes), which were placed within the sediment. The idea being that interstitial pore water from the sediment flowed into the dip wells and the sensors measured the parameters within this water. In practice, this was not carried out and sensors were pressed directly into the sediment. Both pH and redox sensors used a solid polymer reference junction to prevent blocking of the junction by bacteria and diatom films and contamination of the reference cell. Redox used gold as the working electrode.

The various sensors were calibrated according to the manufacturers instructions using the Time Tag software provided with the logger. Importantly, the sensors themselves are calibrated and yield results, which are traceable to internationally, recognised standards and thus results are comparable between different sets of equipment (such as the data logger used on the Vrouw Maria). Logging rate was selected using this software and the information uploaded to the logger. The battery life depended on the frequency of logging. The internal batteries are metal hydride technology but an external pack can be fitted for extended operation. The design aim was that the loggers could be placed for three-month intervals

logging every 20 minutes. Loggers were placed just above the seabed on specially constructed frames. The system conserved power by powering up just long enough to take the various measurements. Data was recovered to a laptop PC using the TimeTag Windows software on retrieval of the logger.

Two data loggers were purchased for each site. One was to be placed on the site and the other kept in reserve should problems arise. The loggers were delivered to the project partners in May of 2002. However, in the first year of deployments a lot of technical problems were encountered. Electrical shortcuts, severe pitting-corrosion, defective underwater connectors and broken wipershafts resulted in a disappointing rate of coverage. Besides these problems some sensors became available almost at the end of the project. Fortunately many of these problems were overcome and solved in good cooperation with the manufacturer. Parallel to this process a series of calibration procedures in cooperation with the Royal Netherland Institute for Sea Research were developed and are now carried out on a routine basis.

6. Results

The data loggers were placed and the following data gathered on the two sites at the times listed in Tables 3 and 4.

One of the problems that became quickly apparent on both sites was the extensive fouling of the sensors and loggers, which affected measure-

Date	Temp.	Depth	Salinity	Dissolved Oxygen	pH	Redox Potential	Turbidity	Sediment Level
05.11.02 - 12.02.03	√	√	√	√	√	√	√	-
13.02.03 - 06.05.03	√	√	√	√	X	X	√	√
07.05.03 - 28.08.03	√	√	√	√	√	√	√	√
31.08.03 - 04.12.03	√	√	√	√	X	√	√	√

Table 3. Summary of data obtained from the Darss Cog site (see next page for legend).

Date	Temp.	Depth	Salinity	Dissolved Oxygen	pH	Redox Potential	Turbidity	Sediment Level
11.06.02 – 11.07.02	√	√	X	√	√	√	√	-
12.07.02 – 29.08.02	√	√	√	√	√	√	√	-
29.08.02 – 17.12.02	√	√	√	√	√	√	√	-
17.12.02 – 26.02.03	√	√	√	√	X	X	√	-
02.06.03 – 29.08.03	√	√	√	X	√	√	√	√
29.08.03 – 15.01.04	√	√	X	X	√	√	X	√
16.01.04 – 19.03.04	√	√	√	√	√	X	√	X

Table 4. Summary of data from the BZN10 site.

-: Device was not available for trialling before February 2003

√: Data successfully collected (or collected for part of the period)

X: Data not collected successfully

ments and should be borne in mind with the interpretation of the results. Examples of the extent of fouling are shown in Figures 2-4.



Figure 2: Data logger on Darss Cog site showing fouling.



Figure 3 & 4. Dataloggers from BZN10 and Darss cog (respectively) showing floral and faunal fouling of the sensor heads.

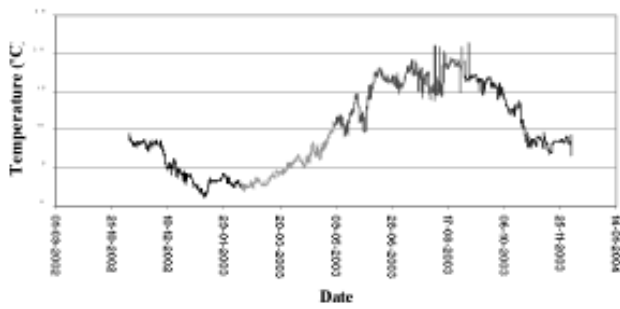

Figure 5. Temperature data from Darss Cog.

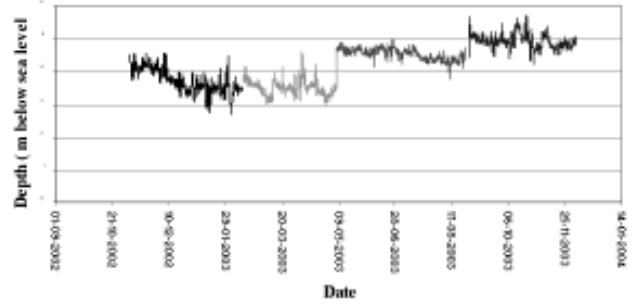

Figure 6. Depth data from Darss Cog.

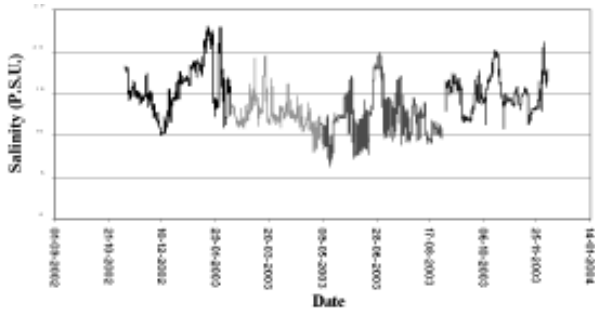

Figure 7. Salinity data from Darss Cog.

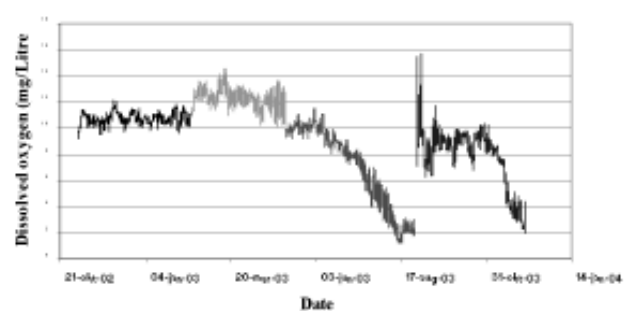

Figure 8. Dissolved oxygen content data from Darss Cog.

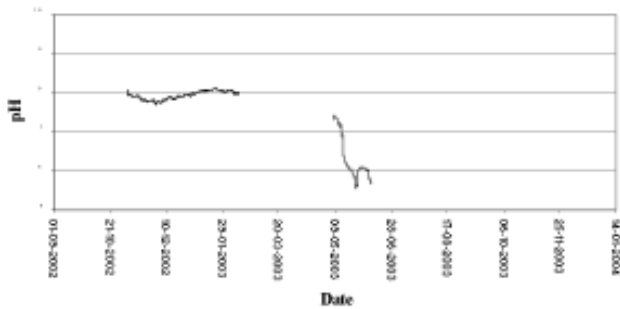

Figure 9. pH data from sediment around Darss Cog.

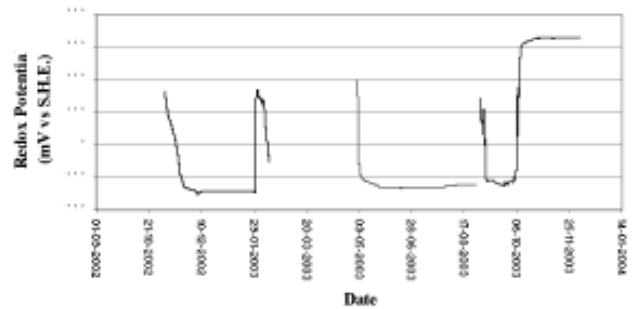

Figure 10. Redox data from sediment around Darss Cog.

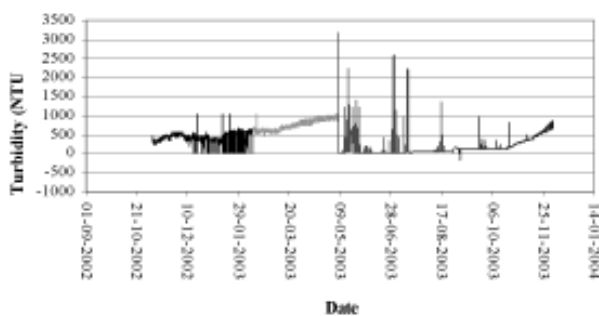

Figure 11. Turbidity data from Darss Cog.

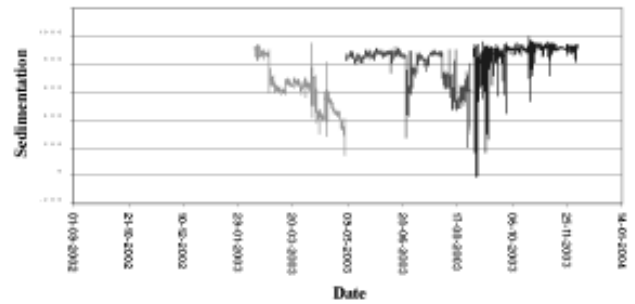

Figure 12. Sediment Level Device data from Darss Cog.

Graphical representations of the overall results are shown in Figures 5 – 12 for the Darss Cog site and Figures 13 – 20 for the BZN 10 site.

—	05.11.02 – 12.02.03
—	13.02.03 – 16.05.03
—	07.05.03 – 28.08.03
—	31.08.03 – 04.12.03

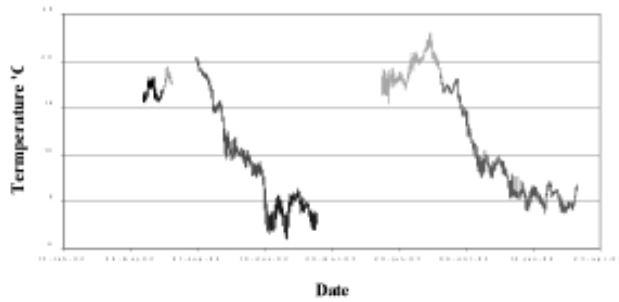

Figure 13. Temperature data from BZN 10.

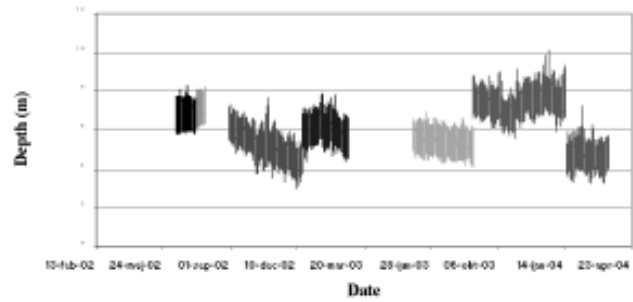

Figure 14. Depth data from BZN 10.

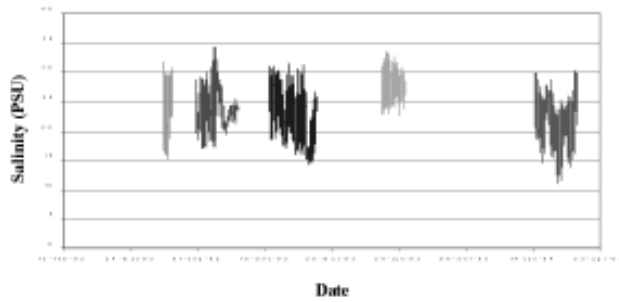

Figure 15. Salinity data from BZN 10.

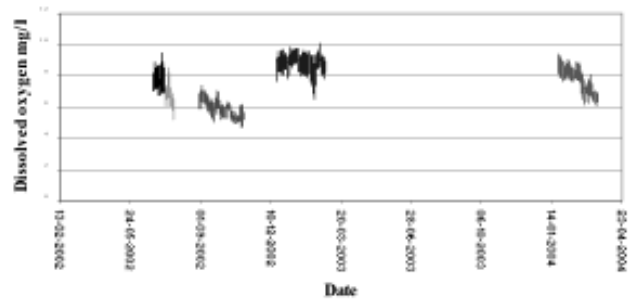

Figure 16. Dissolved oxygen data from BZN 10.

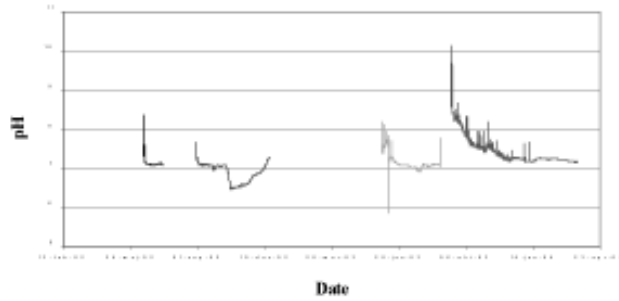

Figure 17. pH data from BZN 10.

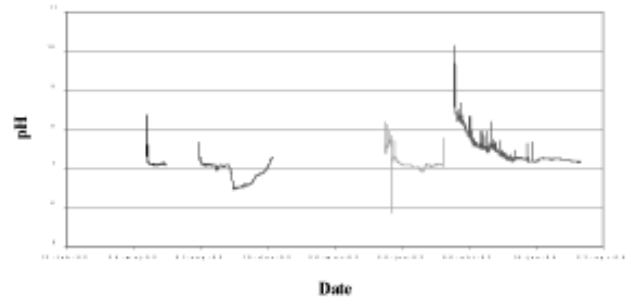

Figure 18. Redox Data from BZN 10.

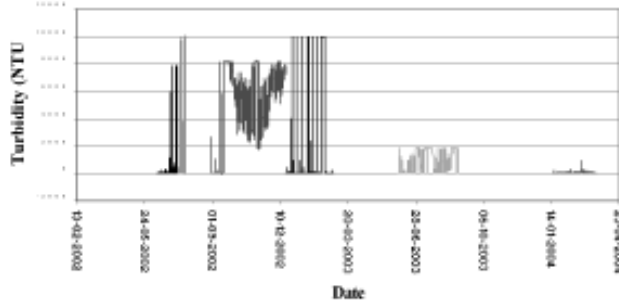

Figure 19. Turbidity data from BZN 10.

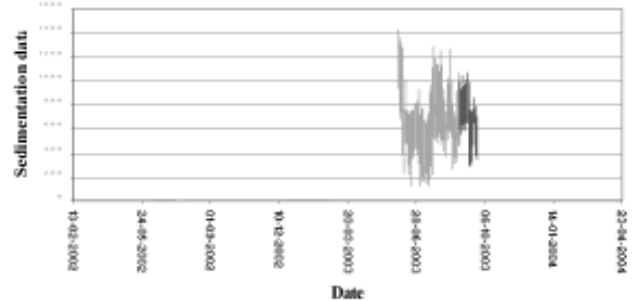

Figure 20. Sediment level data from BZN 10.

—	11.06.02 – 11.07.02
—	12.07.02 – 29.08.02
—	29.08.02 – 17.12.02
—	17.12.02 – 26.02.03
—	02.06.03 – 29.08.03
—	29.08.03 – 15.01.04
—	16.01.04 – 19.03.04

7. Summary of Results

7.1 The Darss Cog

7.1.1 Parameters in open water

7.1.1.1 Temperature

The temperature sensor of the logger performed well during the entire logging period. Seasonal fluctuations in temperature could be distinctly seen with minimum temperatures recorded around December of 2002 and a maximum in August of 2003. The temperature range was from 2.8°C – 20.8 °C.

7.1.1.2 Depth

The Depth sensor apparently functioned well but it appears that the values need to be corrected for the logger's height above sea level when it was calibrated. The cog, according to dive records, lies at a depth of 6m +. This will be investigated and the results corrected accordingly.

7.1.1.3 Salinity

Although the salinity profiles are somewhat "jagged" the overall trends show increase in salinity during the winter periods and lower salinity during warmer periods. This correlates quite well with literature on salinity and temperature. The range of salinities recorded is from a maximum in December of 2002 and a minimum in May of 2003. The salinity range was from 7 – 23 ‰. The reasons for the jagged profile may be that the conductivity sensor had become fouled as the Darss site is very dynamic and fouling of the logger was a problem.

7.1.1.4 Dissolved oxygen content

Initially produced reasonable results. The first two periods of logging (05.11.02 – 12.02.03 and 13.02.03 – 16.05.03) yielded results which correlate with what could be expected

from the temperature and salinity measured at that time. The slight increase in dissolved oxygen measured during the second period, is more than likely an artefact of poor calibration of the sensor or, drift of the sensor. The subsequent two periods of measurement (07.05.03 – 28.08.03 and 31.08.03 – 04.12.03) show that there may be problems with sensor function. This is based upon the fact that taking into account the temperature and salinity at the same points the dissolved oxygen would be expected to be around 6 – 7 mg / litre. Furthermore, the water column around the site does not appear to be well-stratified and thus such a low concentration is unlikely. Finally, during the last phase of monitoring when the logger was replaced on the 31.08.03 (three days after it was removed) the dissolved oxygen content is around 8-9 mg / litre. It is not known whether the sensor was refurbished in between the recovery and deployment but the similar tailing after approximately 3 months may suggest that the sensor requires replacing or recalibration. It may also have been due to fouling. From the data a range between 8 and 12 mg / Litre can be tentatively surmised.

7.1.1.5 Turbidity & Sedimentation Device

When the complete range of turbidity and sediment layer data are plotted the results are

exceedingly difficult to interpret. However, when plotting them on a much finer temporal resolution, i.e. one weeks data, trends can be seen. Figures 21 and 22 show overlay graphs of depth on the site with the turbidity and sediment level results respectively.

Around the 14th of August 2003 a decrease in water depth is seen which continued until the 15th of August, whereupon the water level over the site had dropped by almost 60cm. The turbidity sensor showed increased amounts of sediment in the water column during this change in water depth and the effects were particularly noticeable almost one day after this event. Similarly the sediment level device shows a good correlation with this event with higher sediment levels being recorded. Due to the lack of tidal flow in the area it is being investigated whether or not this is due a climatic effect such as a storm event.



Figure 21. Overlay of depth and turbidity data from August 2003 at Darss Cog site.

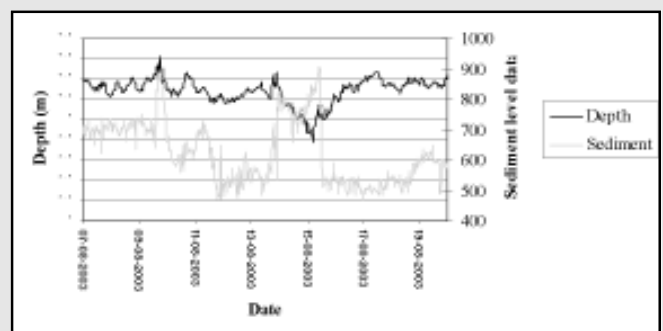

Figure 22. Overlay of depth and sediment level data from August 2003 at Darss Cog site.

7.1.2 Parameters within sediment

7.1.2.1 pH

The pH sensor only functioned on two logging periods, 05.11.02 – 12.02.03 and 07.05.03 – 28.08.03 respectively. The results from the first logging phase appear reasonable for a typical marine sediment with pH ranging from 7.8 – 8.1. The pH results during the second set of data are initially satisfactory yet rapidly decrease to 5.5 which is highly unlikely and may be a problem with sensor stability, bio fouling of the membrane surface or the fact that the sensor should have been replaced.

7.1.2.2 Redox

The redox sensor functioned on three occasions, 05.11.02 – 12.02.03; 07.05.03 – 28.08.03 and 31.08.03 – 14.12.03 respectively. On all occasions the potential recorded was between -250 and -300 mV (vs S.H.E.) which is indicative of strongly reducing conditions which could be expected in a marine sediment. The time lag in obtaining stable results is very often seen with continually measured redox potentials, and should be seen as a real effect rather than an artefact of the measurements. One concerning factor was that the potential on the first and last logging phases rapidly increased giving unrealistic potentials. It is not known whether there were storm events or some other disturbance of the logger and sensors at this point. This problem with the sensor requires investigation. This problem was not experienced during the second phase of logging and brings into question the stability and lifetime of the sensor or whether there is a problem within the logger itself.

7.2 The BZN 10

7.2.1 Parameters in open water

7.2.1.1 Temperature

The temperature sensor of the logger performed well during the entire logging period. Seasonal fluctuations in temperature could be distinctly seen with minimum temperatures recorded around December of 2002 and January 2004 and maximum temperatures in September of 2002 and 2003. The temperature range was from 2.0°C – 22.5 °C.

7.2.1.2 Depth

The Depth sensor functioned well but it appears that the values need to be corrected for the logger's height above sea level when it was calibrated. The wreck, according to dive records, lies at a depth of 7m +. This will be investigated and the results corrected accordingly.

7.2.1.3 Salinity

As with the Darss Cog site, the salinity profiles are somewhat "jagged" and are not easy, even at a high temporal resolution to confidently identify seasonal trends as with the Darss Cog. The reasons for the jagged profile may be that the conductivity sensor had become fouled as the Darss site is very dynamic and fouling of the logger was a problem. From the data obtained the salinity is seen to range between 12 and 33‰.

7.2.1.4 Dissolved oxygen content

The sensor performed reasonably well between the 11.06.02-11.07.02,

12.07.02-29.08.02, 29.08.02 - 17.12.02 and 16.01.04 19.03.04. Giving a range of dissolved oxygen values of between 5 and 10 mg/ litre. There appears to be a gradual drift with time suggesting there may be problems with the sensor yet as there are no real continual data sets this may be an effect of seasonality – maximum levels are recorded during the winter and minimum levels during the summer as may be expected.

7.2.1.5 Turbidity and Sediment Level

As with the Darss Cog data, when the complete range of turbidity and sediment layer data are plotted the results are exceedingly difficult to interpret. However, again plotting them on a much finer temporal resolution, i.e. one week's data, the effects of the tidal cycle are clearly visible. Figures 23 and 24 show overlay graphs of depth on the site with the turbidity and sediment level results respectively.

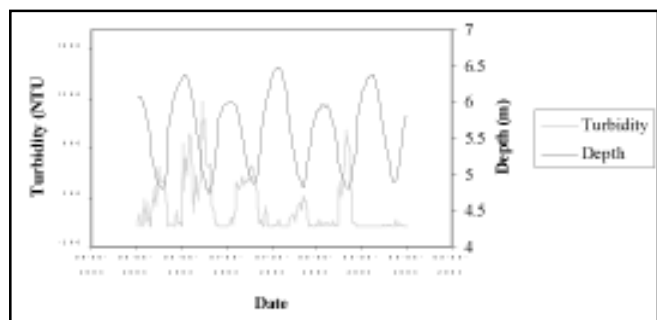

Figure 23. Overlay of turbidity and depth data for 05. – 09.06. 2003 BZN10.

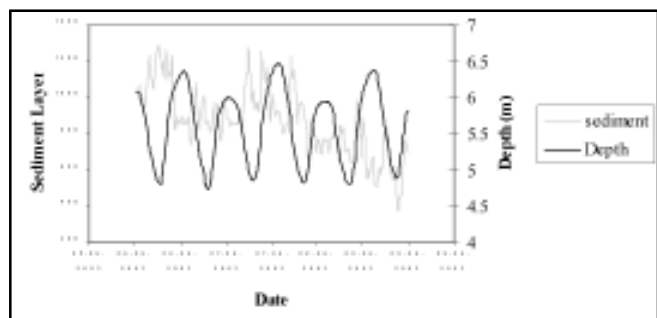

Figure 24. Overlay of turbidity and depth data for 05. – 09.06. 2003 BZN10.

The results, very interestingly, show a clear relationship between the state of the tidal cycle and when sediment transport is at its highest. When considering the turbidity data it can be seen that the sediment loading within the water column increases in the last phase of the ebb tide and then drops off significantly with the flood tide only to be repeated with the next tidal cycle. The sediment data supports this with highest levels of sediment being deposited during the flood tide. The results indicate that the site is certainly very dynamic with continual sediment movement. However, without knowing how the sediment instrument is calibrated it is uncertain how much sediment is being moved at a given time. This would be an interesting point to investigate further.

7.2.2 Parameters within sediment

7.2.2.1 pH

The pH sensor functioned reasonably well although there are occasional spikes in the data. The range of values obtained, when the sensor was functioning, was 6.5 and 7.5 which is reasonable for a typical littoral marine sediment. Again, the stability and working life of the pH sensor is brought into question

7.2.2.2 Redox

The redox sensor functioned on three occasions, 11.06.02 – 11.07.02; 29.08.02 – 17.12.02 and 29.08.03 – 15.01.04 respectively. The potential varied between –230 and –290 mV (vs S.H.E.) which is indicative of strongly reducing conditions which could be expected in a marine sediment. The time lag to when stable results were obtained was much quicker than on the Darss cog. The problem of the signal increasing towards the end of the measurements was not experienced on the BZN10

so whether the question with the Darss Cog is actually a problem within the logger itself maybe a factor rather than the sensor itself.

8.1 Open Water Parameters

8.1.1 Salinity, Temperature, Dissolved oxygen

If we refer back to Table 1 for the parameters that affect the distribution of wood boring organisms we can see that on all sites, the temperature and dissolved oxygen content would not be the limiting factor for wood borer activity. However, salinity does vary over the three sites and one of the reasons that the Vrouw Maria may be so well preserved is that the salinity is well below the tolerance of the wood boring *Teredinids* and *Limnoriids*. Likewise it can be seen that generally the salinities over the other sites is optimal for the growth of wood borers - the range of wood borers and the extent of their activity will be confirmed by the analysis of the wood blocks.

8.1.2 Turbidity & Sediment Level

The Darss cog site, from the data available, does not appear to be as dynamic as the BZN 10 site, based on the turbidity, sediment and depth data. Sediment transport on the site is apparent yet it is not sure if this is climatically controlled (e.g. storm events) and is an area which will

receive further attention.

The site of the BZN 10 seems to be extremely dynamic with sediment transport occurring on every low tide of the tidal cycle. From the data available it is difficult to quantify how much sediment is being transported. When functioning the turbidity and sediment sensors gave a good indication of sediment transport.

8.1.3 Sediment characteristics

When the pH and redox potential are taken into consideration we can see that the environment is almost neutral in pH and the redox potential is very similar for both the Darss Cog and the BZN10 sites and indicates strongly reducing conditions. The redox processes ongoing on the sites are highly likely to be dominated by sulphate reduction, mediated by sulphate reducing bacteria, which are ubiquitous in marine sediments and thrive at the potentials measured. These conditions should in theory be ideal for minimising microbial attack and bacteria will probably dominate the inevitable slow deterioration of the wood in these conditions. Again correlation with the results from the wood blocks will confirm or refute this hypothesis.

Parameter	Darss Cog	BZN 10	Vrouw Maria
Temperature (°C)	2.8 – 20.8	2.0 – 22.5	3.22*
Depth (m)	ca 6	ca. 7	ca 40
Salinity (PSU)	7 – 23	12 – 33	6.57*
Dissolved oxygen (mg / Litre)	8 – 23	5 – 10	6.10*
pH	7.8 – 8.1	6.5 – 7.5	7.12 [§]
Redox potential (mV vs SHE)	–250 – –300	–230 – –290	+420 [§]

*: Average results From Riikka Hakala et al.

§: Measured in open seawater not sediment.

9. Conclusions and recommendations

By Sven Ober

(Who coordinated field use of the dataloggers)

The EauxSys Watch Water System 2681 was developed specifically for the MoSS project to measure a range of parameters relevant to the deterioration of wooden shipwreck material in the marine environment. In open water temperature, depth, salinity, dissolved oxygen turbidity and sediment level were measured. Within sediments pH and redox were measured. Initial technical problems with both software and hardware were encountered which have generally speaking been resolved through good cooperation with the manufacturer. The system is now a reliable platform for this kind of work and is a useful tool for monitoring various parameters, which affect the deterioration of shipwrecks. The modular nature of the system also means that different sensors can be added to the logger should other parameters relevant to the degradation of shipwrecks become apparent. Of course, this would involve further development but the potential is there. Some of the sensors are close to perfect and do not need much attention (temperature, pressure, OBS/Turbidity), the conductivity-sensor (for determining salinity) and the dissolved oxygen-sensor are quite good but need regular calibrations and maintenance. The pH-sensor and the redox-sensor do not appear very reliable. They do still have a tendency to show erratic behaviour. However, this may also be a question of validating the method of deployment. The sediment-sensor became available almost at the end of the project so not much experience could be gained. Although initial results look promising, it would be interesting to try and quantify the amounts of sediment either in the

water column or over the sediment device. Based upon all the data up to now a few recommendations for the near future can be formulated:

1. Try to replace the pH- and redox-sensor by sensors from a reliable brand e.g. Seabird
2. Try to replace the DO-sensor by a sensor that is based on fluorofores. This new technology became available in 2002 and is at least 10 times more stable and accurate than the technology used at present.
3. Protect the sensor head with a sacrificial cage of copper or brass to reduce the biofouling and increase the quality of the conductivity.
4. Try to limit the deployments to 2 months and increase the sampling rate.
5. Mount the logger at least 50 cm from the sea bottom. This will reduce the influence of sand on the conductivity measurements.

Further recommendations: David Gregory:

1. Train researchers from the Institutions deploying the data loggers to calibrate the loggers. A short course in the principles of calibration would enable the sensors to be calibrated on the day and on the site where it is to be deployed. If there is not good calibration, as we have seen, much time and effort can be wasted.
2. In relation to this the preparation of a manual aimed at archaeologists / conservators with a simple step by step guide through the preparation of calibration solutions and their use and a trouble shooting guide. Such a manual should include the process of downloading data, transferal to an Excel spread sheet and basic quality control of the data.
3. Post deployment calibration should be carried out to check for any drift in the sensors. It may then be

possible to correct for this.

4. Refurbishment or replacement of sensors on a regular basis. It would appear that pH and redox sensors have a lifetime of 2-3 months. This should be borne in mind when planning the deployment of the logger. These sensors are relatively cheap (ca. 200 Euro at time of writing) and in my opinion should be replaced after every deployment. The dissolved oxygen sensor can and should be refurbished every time (a refurbishment kit costs ca. 100 Euro and is sufficient to refurbish a sensor 6 times).

Improved quality control of data. All data was with the present author only 3 months before the completion of the project. Once data has been downloaded, it should be checked immediately. As has been seen with this report the quality of data was in certain cases not of a high quality. In part this was due to problems with the sensors but in part this was due to bad operating procedure and not highlighting potential problems early enough (re pH, redox and dissolved oxygen). This initial quality control is not time-consuming involving conversion of the Time Tag data to Excel and preparation of graphs of the data. Thus gaps in data can be seen and general trends / drifts immediately spotted.

Visualizing Underwater Cultural Heritage in the MoSS-project

Introduction

The English concept of visualization comes out of the word visual, - which in turn is derived from the Latin word visus, meaning sight, where videre, to see, is the verb. Visualization as a term is closely related to our capacity to see. Maritime Archaeology is very much about the transference of visual information to the public.¹ We wanted this to be one of the main themes in the MoSS-project. At the same time visualization is a way of reaching a better understanding of underwater sites for purposes of safeguarding and monitoring underwater cultural heritage, which were the two other main themes in the project.

As a starting point we thought that it was important to be able to differentiate clearly between objective information, i. e. documentation, and the interpretation of documented facts.² We wanted to use methods that have proven to be reliable in underwater archaeology in recent decades and we also wanted to test and develop new ways of collecting data during the documentation process. We wanted to get as much objective information as possible and tried to find methods, which would make the documentation process faster and easier even in the difficult conditions which resulted from cold water, depth and darkness. Reliable visualization can only be based on good documentation and we didn't want to compromise on this.

Visualizing underwater Cultural Heritage is essential for several reasons. Cultural heritage is common; it belongs to all of us and therefore we should all have the



A replica of the Eric Nordevall under construction in Forsvik.

possibility to experience these sites. Even though in theory we could all dive, these sites are often so delicate that they cannot endure mass-tourism. Often these sites comprise little more than broken pieces of wood lying around the seafloor; they need a specialist to provide an interpretation, which will aid the public in helping to see the way the ship was originally. For a specialist this requires good knowledge of the subject as well as the practical tools to provide the visualization. In the MoSS-project we have used different kind of techniques and in this section of the Final Report we want to pass on our experiences of visualizing underwater cultural heritage.

The Nature of Visualizing

As long as there has been Maritime Archaeology, there has been visualizing. It is an essential tool to transfer information to the public. It is not very common to be able to separate fact from fiction in models,

which have been and still are used to visualize archaeological heritage. Models are the representation of our interpretation of a site, which is accepted at the time of model making. Until now they have not included the idea that the concept may change in the light of new information, they have been more like final products. This is partly due to the nature of archaeological work, as the results of archaeological excavations are visualized soon after they are carried out. The idea behind this practice might possibly be the thought that a site could only be investigated once and therefore visualized only once. But now it is possible to find new ways of looking at the evidence, of "reading the past" after years of excavations. With the use of modern techniques, such as video cameras, information becomes more objective. These new techniques allow us the possibility to make visual products more reliable.

¹ Cederlund 2004: What is visualization?

² Jöns 2004: Techniques of Documentation and Visualization.

The first drawings made of the wreck of the *Vrouw Maria*, soon after it was discovered, were thought to look exactly like the wreck. However, after three years of the MoSS-project there is now a drawing, which looks totally different, and yet we cannot be certain that even this is the final version of the drawing. These drawings are called "artists views", because the information in them is collected from different videos and photographs and interpreted by an artist. It is very hard work to put all the pieces of the puzzle together and after every drawing one gets a feeling that someone has set a light to the darkness. Every drawing is important in the process of visualizing a wreck like the *Vrouw Maria*, and by putting these drawings in line one can easily see the change in the amount of information, which has been collected from the wreck.

What we were visualizing in the MoSS-project

We were required to visualize four different types of old shipwreck, their sites, their degradation process and the ships as they were originally. Our Dutch colleagues undertook visualizing through the use of contemporary evidence (see also Oosting, p. 52). The four wrecks were the *Eric Nordevall* in lake Vättern, *Burgzand Noord 10* in the Wadden Sea, the *Darss Cog* and the wreck of the *Vrouw Maria* in the Baltic Sea. These four shipwrecks, which are of great historical significance, were visualized for Europeans to help convince them of the importance of preservation and of the necessity of the sustainable safeguarding of our underwater cultural heritage.³

In the different sites the scope of the visualization differed as it depended

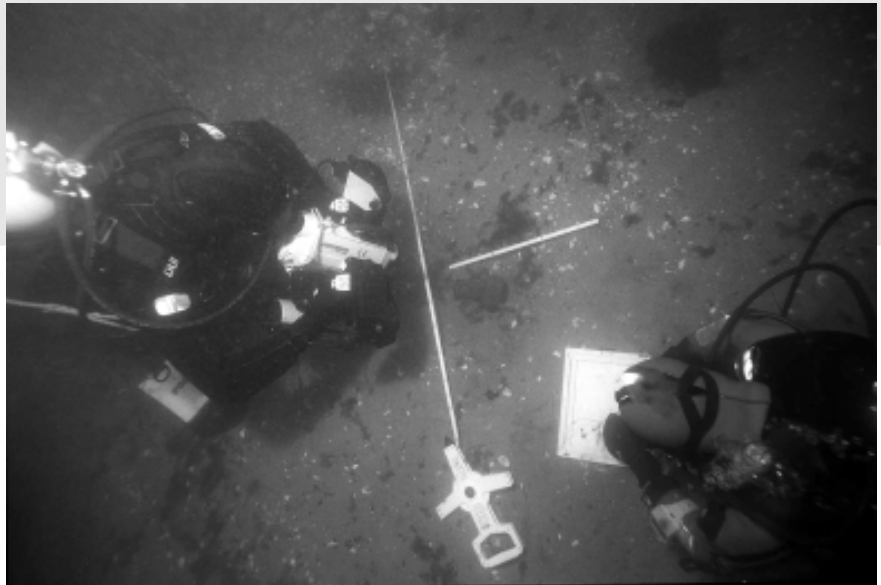

A diver filming with a video camera at the Darss Cog.

on the on-site conditions and the actual need for the visualization. The state of the wreck's preservation also had a strong influence on the method-

ology employed as from these four wrecks, two had only parts of the hull left intact and sediment mostly covered these parts. For example, the



A model of the *Vrouw Maria* visualizing the work of maritime archaeologists.

³ Jöns 2004: Techniques of Documentation and Visualization.

general map of the site of Burgzand Noord 10 was produced by using standard methods such as taking measurements with the webit-program, and then adding the results to the video images and drawings. From there on the idea was to follow the degradation process while using a new technique such as OPUS 3D. Of the four wrecks, the Darss Cog had the most advantageous visibility conditions. The wreck lies at a depth of only 6 meters where the conditions for photographing and videotaping are good. For this reason, the wreck was chosen to test and develop underwater photogrammetry (see Kresse, p. 57).

The hull of the wreck of the Vrouw

Maria was very well preserved as were the different parts of its rigging. The Vrouw Maria's wreck was therefore used to visualize the original ship as if it were in a 3D model with the use of the Rhinoceros-program (see Wessman, p. 61). This 3D model was used to make an old fashioned model of the wreck site, where a model of the research ship is floating above the wreck at sea level. The model thus visualizes the work of maritime archaeologists in the field, a view that is not normally accessible to the general public. This kind of model may be old fashioned in other parts of Europe, but in Finland this is the first one of its type and it will be presented in an exhibition at the Maritime Museum. The visualizing

process has gone even further with the fourth wreck, the Eric Nordevall, where a full-scale replica of the ship has started to be built by a group of enthusiasts belonging to the Forsvik Shipyard Association.⁴ With the help of this replica visualizing through participation has come closest to being an authentic experience, where history has come alive!

For more information see the Newsletter 1/2004 Theme: Visualization.

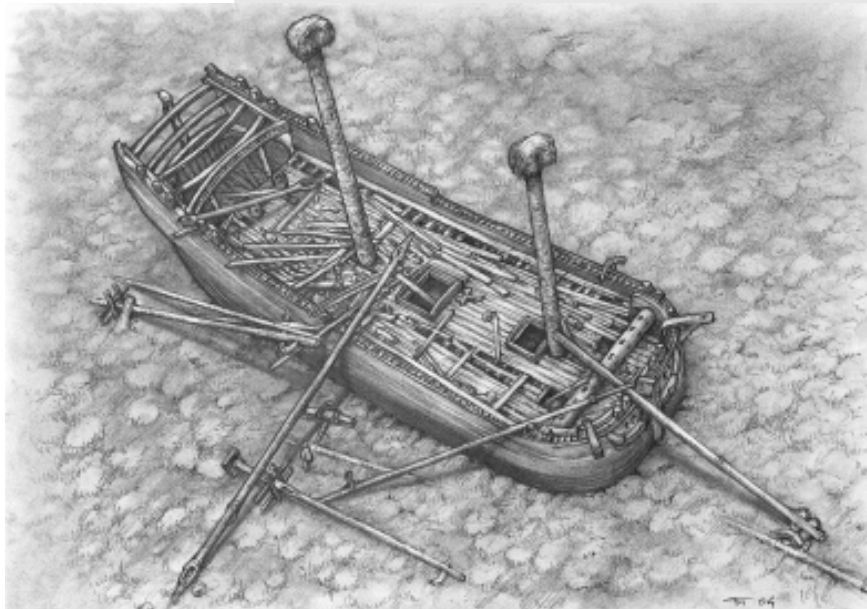

An artist's impression of the wreck of the Vrouw Maria. Drawn by Tiina Miettinen, The National Board of Antiquities, 2004.

⁴ Cederlund 2004: Visualisation through Participation.

The Four Wrecks of the MoSS Project, Their Time and Cultural Settings

Both the remains of the original ships and the full-scale copies of them are well suited to create a stage on which we can enact the life of a period that was generations ago. They are scenarios containing not only a ship's visual historical information but they also offer us the possibility to create an environment in and around them.

To visualize is in this context not only to transfer proper visual information - but also to set a scene from the past. This makes us the directors of this process - with the responsibility and the freedom this brings.

From a bird's eye perspective we will discuss the historical background of the four shipwreck sites in the MoSS-project and their place in maritime history in chronological order.

The Darss Cog: a merchantman of the hanseatic period

By the time the oldest ship in the MoSS project - the Darss Cog - was built in around the year 1293, the Baltic Sea had already been a large common market for about 100 years. It was organized by the well-known Hanseatic League that used the enormous cargo capacity of the medieval cogs to transport goods and wares in amounts that had never been known before from production areas to consumers in all parts of the known world connecting for example Russia and Prussia in the east with Denmark, England and Holland in the west.

The profit from this business, which was permanently increasing, was the basis for the rapid development of the hanseatic towns, especially those that were established in the southern Baltic area. After the final defeat of the Slavonic tribes that had been living



The water-tower of the hanseatic town Wismar was built during the Hanseatic period near the harbour. Today it is visualising the architecture of these days (Bernd Wollschläger, ALM MV).

there for about 400 years, thousands of West European farmers, handicrafts-people, traders and knights spread into the coastal areas and founded new villages, castles and towns. Lübeck, Wismar, Rostock, Stralsund and Greifswald - just to mention those hanseatic towns situated in present day German territory - were all founded in this period.

Based on the expanding economy, which mostly depended on sea faring and trade, new shipyards in the estuaries of the big rivers, especially

those of the Oder and Vistula were established. The first generation of cogs constructed there were built according to the Frisian shipbuilding tradition although the timbers that were required were taken from the forests of the region. The Darss Cog, constructed somewhere in the Vistula estuary, belongs to this type of cog. However, by one or two generations later, the construction of the ships had gradually changed and this led to the development of the Baltic's own ship building tradition.

The findings from the Darss Cog can



The monastery church of Bad Doberan was built in the late 13th century and the early 14th century. The roof-tiles for this church have been transported on ships like the Darss-cog (Klaus Winands, ALM MV).

help us to reconstruct and visualize the life of the ship at that time. Its cargo consisted mainly of whetstones of mica schist from Norway, reindeer antler from northern Scandinavia and Sulphur probably of Icelandic origin. This indicates that the ship was probably following a typical trading-route from Bergen, Oslo or Tønsberg heading for a hanseatic town on the southwestern Baltic coast, when it sank in around the middle of the 14th century in the Darss area.

From the 15th century onwards, the leading role of the Hanseatic League gradually diminished and the main maritime centre shifted from the Baltic to the Atlantic Ocean. The main market came to be that of the city of Antwerp. Trade flourished but when in 1585, during the 80 years war between the Netherlands and the troops of Philips II, the latter took Antwerp, and its leading role was taken over by Amsterdam. Despite this war, commerce was booming.

Ships arrived from all wind directions and they had to get bigger in order to be able to keep up with the demands of the market. These big ships were not able to get into the harbour of Amsterdam, since the Zuyder Sea was too shallow. Instead, they stayed on the Texel Roads where the merchandise was loaded and unloaded into smaller ships ("lichters") that transported the goods to and from Amsterdam.

The Burgzand Noord 10: a ship and its cargo lost on the Texel Roads

The Texel Roads area in the Wadden Sea is the place where the Burgzand Noord 10, an unknown trading ship, sank in the second half of the 17th century. The Texel roads were protected by the Island of Texel from the Western winds and were therefore

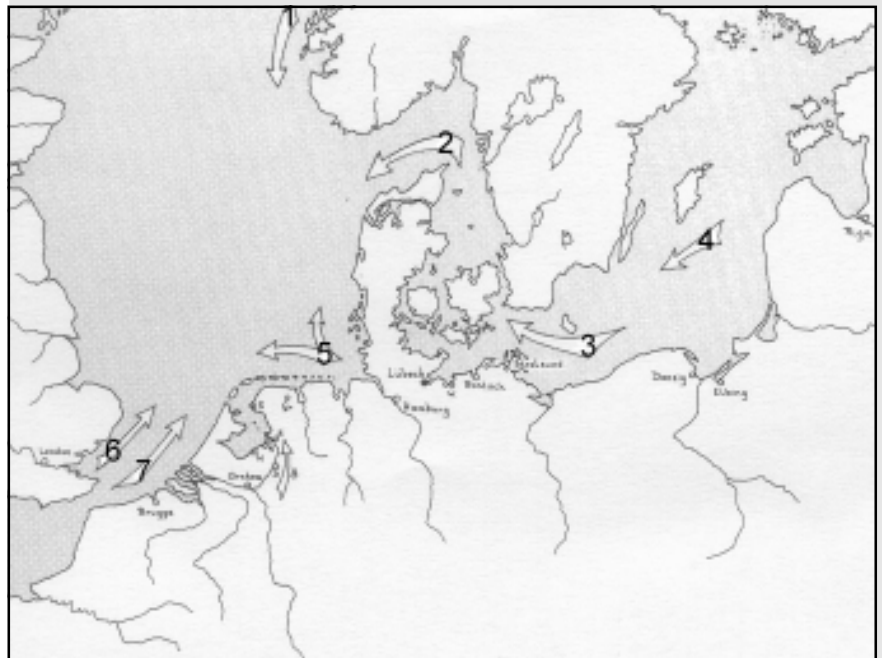

Trade routes of the hanseatic period.

1. stock-fish
2. pelts, tar
3. wood, grain
4. wood, pelts
5. beer
6. wool, pewter, coal
7. salt, wine

a good place to anchor. However, the wind occasionally blew from a different direction and during these kinds of storm many ships sank. This also happened with BZN 10. The ship doesn't seem to be Dutch. It might have been built in Northern Germany since it is constructed in a way that still remains to be ascertained with the use of pinewood from this area. The earthenware used on board is also from northern Germany.

The ship was wrecked in a turbulent period. In 1648, the 80 years war finally came to an end and the Treaty of Munster was signed. However, soon after, the first of four Anglo-Dutch wars started (1652-54) which was quickly followed by the second (1665-67). It got worse; 1672 was a disaster as the Dutch became embroiled in war with France (1672-78), England again (1672-74), Munster and Cologne. Although these wars affected the trading of goods, Amsterdam remained the most important market, especially for the exchange of money. It seems as though the BZN 10 had a cargo destined for the Amsterdam Market. It consisted of Iberian jars filled with a white substance that might have been bentonite earth and urine, which was used for the production of wool. Casks filled with grapes and fish and chests with schist slate roof tiles were also part of this cargo. This, together with the fact that the ship was armed with at least 10 cannons indicates that the BZN 10 was involved in the trade to the south, the route through the street of Calais to the Iberian Peninsula. After the Treaty of Munster, the trade with Spain, which had actually never stopped, became normalized and started growing. This route was full of danger. There were privateers everywhere that were looking for ships and cargo to capture. This is why the ships that went in that direction were



Scale model of the Texel Roads, on exposure in the Maritiem and Juttersmuseum on the isle of Texel.

more heavily armed than ships trading with the Baltic, which at that time was a relatively safe area. Although the ship BZN 10 survived all this, it was unfortunately struck by nature and sunk during a storm.

In the 18th century, the market of Amsterdam and the Dutch merchants themselves experienced growing competition from other countries. Dutch merchant ships were no longer seen in the Baltic as often as they had been before: While Dutch ships accounted for a third of all vessels calling at St. Petersburg in the 1720s,

their share fell steadily to under 10 percent by the 1780s. At the same time, the English and the French merchant vessel fleets grew larger than the Dutch one.

Nevertheless, for fine goods especially, the Amsterdam market was still very important; a lot of money was invested in trading with the East and West Indies. For the rich and famous it was also the place to buy fine art such as paintings from the many well-known 16th, 17th and contemporary 18th century artists.

The Vrouw Maria: a Dutch snow ship wrecked in Baltic waters

When the two masted Dutch snow ship the Vrouw Maria entered upon her last voyage in 1771, a part of her cargo consisted of these fine Dutch paintings bought by the Tsarina in Amsterdam. In St. Petersburg, a fast growing town by this time, there was a big demand for all kinds of western European merchandise. It was there that Catherine the Great had the Winter Palace built in 1754-62. Today the complex is known as the Hermitage, one of the world's biggest museums. The paintings on board the Vrouw Maria were on their way to the Winter Palace when the ship was wrecked off the Finnish coast.

Even though the ship had sunk not all hope was gone that the paintings could be retrieved. The Northern Diving Company, established in 1729, offered its salvaging and diving services along the Finnish coast. The search for the wreck however proved to be fruitless.

Since the cargo consisted of everything from daily trading goods to luxuries, the wreck contains a cross section of socio-economic information about both Western Europe where the cargo derived from and Eastern Europe to where it was going.

In the early 19th century there was a revolutionary change in the construction of ships; the steam engine was developed. In Sweden the steam-propelled ship was introduced in 1816 when the first trial with a steam engine on a ship took place in Stockholm. Just a few years later, around 1820, the first ships driven with steam engines were in business on Lake Mälaren beside Stockholm. It was not until the end of the 19th century that these steam-propelled ships completely replaced sailing ships in



The Winter Palace, St. Petersburg.

Europe, but this invention had some advantages that made these ships very suitable for being used in internal waters. Now, there was no longer any dependency on wind and muscle power which made them suitable for the narrow canals. It also meant that ships could travel from A to B within a specified time schedule.

The Eric Nordevall: a canal paddle steamer wrecked on Lake Vättern

The Eric Nordevall fulfilled its task as

a channel steamer for twenty years. The ship was one of five paddle steamers built in the 1830s for the newly opened Göta Kanal, which crossed Sweden from the Baltic Sea to the West coast.

It sank after having been grounded on a shoal outside the small town of Vadstena in Lake Vättern, on the 4th of June 1856. After some difficulties the steamer was eventually taken off the shoal, but it sank after only a few

hundred metres as it was being towed back towards land. Evidently the damage on the bottom of the hull was such that it took in much more water than could be pumped away. The passengers had however been safely rescued from the stranded vessel. No lives were lost in the accident.

The building of the Göta Kanal was a vital factor for the recovery of Sweden after a turbulent period of history: By 1809 Sweden had lost the war against Russia, and in the peace treaty which followed, it lost one-third of its territory – Finland - which had belonged to Sweden since medieval times. The peace treaty after this war was the worst Sweden had ever signed. As a result of the war there had been a revolution and the king had been dethroned. The country was very near to becoming a military dictatorship and in a very bad situation economically with high inflation, and ever increasing prices. This was because the economy was mainly based on agriculture and several years of crop failure had created very difficult living conditions for the people. The country slowly rose out of this catastrophic situation during the following decades.

When the canal was opened in 1832, it was one of the many steps taken in the development of communications during the 19th century. The route by steam ship from Stockholm to Gothenburg soon became a popular new way to travel, much preferred to the old stagecoach.

Today the canal has become one of the major tourist attractions in Sweden with both passenger ships, the followers of the E. Nordevall, and many yachts and motorboats passing along it during the holiday period. Soon a replica of the Eric Nordevall,

named the Eric Nordevall II, will be used on the same canal so that tourists can relive history onboard by having many of the same experiences that travellers would have had in the nineteenth century.

Conclusions

The four wrecks in the MoSS-project are all unique objects and time capsules from their own periods; the 14th, 17th, 18th and 19th centuries. Individually they can tell us much about the maritime history of these ages, but together they also allow us to see the development that took place over time. The Darss Cog represents the time and trade of the hanseatic period, while the BZN 10 wreck draws attention to the leading role of the Amsterdam staple market and the trade with the South of Europe. The Vrouw Maria represents not only the western trade with the Baltic (East), but also the cultural exchange that was taking place within Europe. The Eric Nordevall is a fine example of the type of inland transport, which was occurring over canals, and of the start of the industrial revolution. Nowadays ships still use these waters and pass these four shipwrecks on their sites, usually without knowing they exist. Hopefully MoSS has helped remove the anonymity of these fine examples of maritime history.

More information

More information about the MoSS shipwrecks can be found in the MoSS newsletters.

Vrouw Maria (newsletter 1/2003)

The Darss cog site (newsletter 2/2003)

The Eric Nordevall (newsletter 3/2003)

Burgzand Noord 10 (newsletter 4/2003)

Text contributions by

Carl Olof Cederlund

Hauke Jöns

Martijn Manders

Rob Oosting

Stefan Wessman

The last results of the photogrammetric mapping of the Darss Cog

1. Introduction

Within the MoSS-Project the University of Applied Sciences, Neubrandenburg is responsible for the photogrammetric mapping of the Darss Cog (see MoSS-Newsletter 2/2003). In this report the last results from October 2003 until March 2004 are summarised. In this period a digital three-dimensional model of the Darss Cog was constructed, using underwater pictures, which were taken in summer 2003. The research group in Neubrandenburg received four small screen colour films 24cm x 36cm in October 2003 from the Archaeological State Museum, which contained photos that would enable an entire model to be constructed by stereo photogrammetry. A preliminary model has now been delivered as a wire-frame model in the DXF-format.

2. Starting Material

Three of the four films could be used for photogrammetry. A photogrammetric block of 102 pictures was calculated for the analysis. Additionally, 17 distances, measured under water, were included in the network adjustment. These distances mainly described the entire length and width of the wreck and served as an independent reference of the length of the photogrammetric block. For six more distances the two end points were determined unambiguously. However, prior to the photo campaign three metal tape measures were spread out on the wreck in a lengthwise direction. They offered small length references with their markers in meter distances. The focal length of the camera was only approximately known.

3. Evaluation

The analysis can be subdivided into five steps: scanning of the pictures, measuring of the tie points, calculation of the network adjustment,

mapping of three dimensional object points and lines with a digital stereo device and cleaning-up of the mapped data.

3.1 Scanning of the Pictures

The photos were scanned with a slide scanner from the University of Applied Sciences in Neubrandenburg. The model was a Dimage-Scan Multi. The scanner was not calibrated for scanning accuracy prior to scanning. However, possible axis errors have only a little effect with such a small picture format. An independent control of the scanning accuracy is offered at a later stage by the results of the network adjustment (see section 3.3). The result can be accepted with a spatial point error of less than $\pm 5\text{cm}$. Concerning our experiences, other errors limit the accuracy to a greater extent, especially the limited detectability of details in some parts of the wreck.

In a previous stage the pictures were scanned with a photogrammetric scanner (Zeiss PS1 PhotoScan) for test purposes. Such a scanner offers a point accuracy of better than $2\ \mu\text{m}$ in the picture. This corresponds to a distance of approximately 0,2mm on the object. However, many dark corners of the scans were not recognizable anymore, so that these pictures were not suitable for mapping. Since high geometrical accuracy was not necessary in this project, we decided to use the geometrically more inaccurate, but more light intense slide scanner.

3.2 Measuring of the Tie Points

For the measuring of the tie points we used the program PhotoModeler Pro 5 from EOS Systems, Canada. This programme actually offers all the necessary steps from point measurements up to network adjustment and visualization of the object. The point

measurement programme was very good. In contrast, the network adjustment was not flexible enough for our task, since the a priori accuracy of the different input elements – tie points, long distances, short distances – could not be controlled finely enough. Additionally, occurring wrong point measurements could not be recognized exactly and eliminated.

Prior to the point measurement of every image the so-called "interior orientation" has to be measured. In small pictures without marks on the frame and reseau-crosses, the corners of the picture, which are in fact pictures of the plant frame of the camera, have to be determined within the picture. Most of the pictures were illuminated well in the centre, but they had one or two dark corners, hence this measurement was crucial. A dark corner does not stand out against the frame. The contrast was just about sufficient at the scans of the slide scanner.

Altogether 774 tie points were measured. There are 7.5 pure linear points per picture. Since every point occurs at least twice per picture, there is an average of 15 points per picture. In fact there are even more because points also occur in more than two pictures. At the maximum end of the scale one point lies in 27 pictures. This number of points offered a high redundancy, so that the network adjustment was still stable after the elimination of 46 points.

Approximately 100 plastic balls with a size of 7cm were nailed to the timbers of the Darss Cog prior to the measurements. Some of the balls were marked with letters from A to Z. The balls worked as an orientation aid for the evaluator and as a pattern for the tie points. The balls and espe-

cially the letters made the orientation much easier. This as well counts for a first viewing of the images without a viewing device.

In the sufficiently sharp pictures many more tie points could be measured on structures in the wood. Within softer pictures this was difficult. Those pictures, that do not contain any texture in whole fields because of their darkness, are problematic.

3.3 Calculation of the Network Adjustment

The program BINGO from the company GIP was used for the network adjustment. The results are characterized by the following parameters: a priori accuracy of the image point measurements: 70 μ m
a priori accuracy of the short distances: 2cm
a priori accuracy of the long distances: 6cm
 σ_0 of the entire network: 75.09 μ m
middle σ_x of the tie points: 19mm
middle σ_y of the tie points: 19mm
middle σ_z of the tie points: 40mm
maximum σ_x of the tie points: 74cm
maximum σ_y of the tie points: 77cm
maximum σ_z of the tie points: 93cm

The long distances had less accuracy, because test runs of the adjustment revealed that the tape measure sagged or was shifted away from the linear connection by currents. As a result an apparent elongation of the distances occurred. The measured distances lay between the edges of the plastic balls. All distances had to be prolonged by 7cm due to the diameter of the plastic balls.

The arrangement of the photo axis is not parallel on all pictures, and shifted in most cases against each other by about 90°. This arrangement enables the use of the so-called simultaneous

calibration of the camera. By this the parameters of the interior orientation of the camera are determined during the network adjustment. The following results were obtained from the calculation:

Calibrated focal length c' : 16.2mm
 x_0' (principle point x): 0.038mm
 y_0' (principle point y): -0.049mm

While the photos are being taken, the camera is under water in an underwater case. In the photo direction this is closed with a semicircular glass cupola, the so-called glass dome. The beams of light from the object to the objective of the camera pass almost perpendicularly through the demarcation area of the glass dome.

Nevertheless, there is a geometric influence by the glass dome on the beams of light. The exact nature of this influence is unknown. When the optical axis of the objective falls perpendicularly through the glass dome, its geometric influence on the picture that has been taken can be modelled radially-symmetrically. Otherwise it is an asymmetric influence. This influence is part of the distortion of the entire object glass dome.

Such an influence can, in principle, be determined under laboratory conditions or as part of the picture analysis. With a measurement under laboratory conditions a test field must be included and measured in the picture. There has to be water in front of the glass dome in a case like this where it has been used under water, to simulate the correct order of the refraction water – glass – air in underwater conditions. Additionally, the camera has to be installed in the same position as it was during the actual photo taking process. This calibration was not carried out.

In our case we attempted to assess

the distortion by using the existing photos. Going out from the pictures through the middle of the tape measure runs, we set the scale of the recognizable tape measure in the 10cm-distance in relation to the measured picture coordinates of the 10cm-markers. Slightly different, but geometrically similar process curves resulted from these measurements in several pictures. We defined an average process curve as the distortion curve, valid for the objective - glass dome - system. The distortion values were applied in the last step of the adjustment as a further form of optimization. The improvement of the σ_0 of the entire network was surprisingly only approximately 2 %.

For the transfer of the complete orientation data for every stereo model to be analysed, files were created in pex-format. This format was defined by the company Zeiss and contains the complete data which are necessary for the creation of a stereo device. If a picture pair with the corresponding pex-file is loaded, one can immediately view the picture pair in stereo and start measuring.

3.4 Three Dimensional Point and Line Mapping with a Digital Stereo Device

The digital stereoplotter PHODIS ST was used for the mapping of the cog. PHODIS ST is part of the Zeiss system PHODIS. It runs on UNIX-workstations of the Silicon Graphics company. Alternatively, we could also have used the system SSK (Stereo Softcopy Kit) from ZI-Imaging. However, its functionality is less flexible for terrestrial-photogrammetric applications, to which the cog belongs. As a third option we could have used the program PhotoModeler. But this program does not offer the possibility of stereo display. However, with the irregular and round shapes of the cog

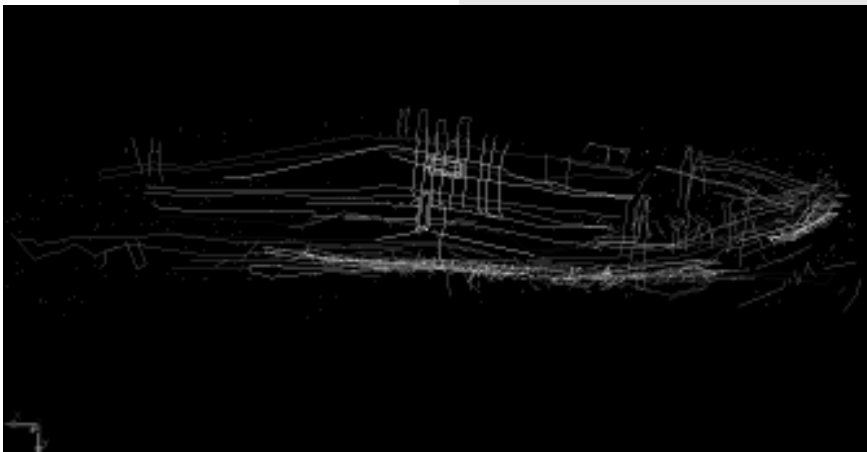
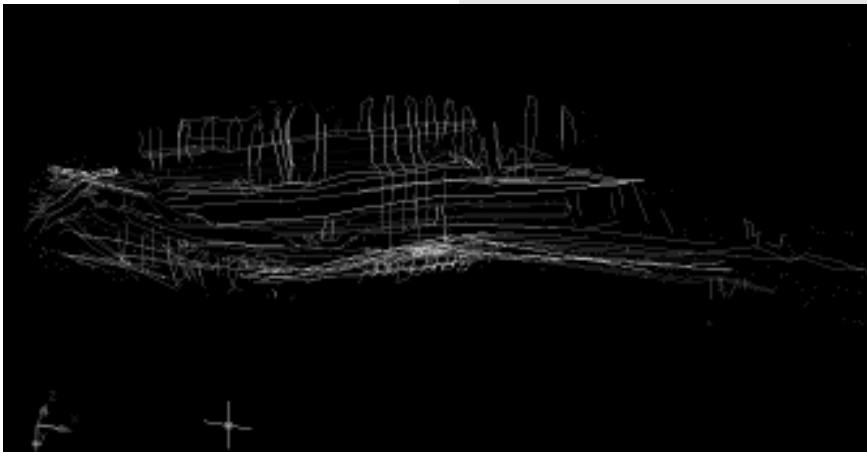

A digital three dimensional model of the Darss Cog based on photogrammetry, showing the wreck from different views (Graph: W. Kresse, Neubrandenburg).

it was also an advantage to be able to place a straight line within a stereo picture pair also on the bended surfaces without edges. A mono data-capture, as with PhotoModeler, always depends on rims and edges. Additionally, previous experience has shown that the point measurement accuracy in a stereo picture is one and a half times better than with a mono measurement. This especially counts when dealing with the unstructured surfaces of timbers at a wreck.

The mapping of the wreck was carried out by using the CAD-program MicroStation. This program is connected with PHODIS ST in such a way, that the three dimensional cursor of PHODIS ST and the PHODIS mouse work as a measurement cursor on a common graphic screen. This allows the individual vectors to be placed in a spatially visual way along the edges of the objects. MicroStation offers a DXF-interface for the output of the completed data.

Stereo viewing is only possible when rather small tolerances are kept during the rotation of the images. A couple of picture pairs were rotated against each other by about 90° or 180° and had to be turned by copying before the measurements.

Stereo measurements require a minimum length of the base. The base is the distance of the projection centres (the objectives) of the cameras. A base that is too small, leads to dragging intersections on the object and therefore makes determination of the height difficult. An ideal base-height-relation is 1:1. With a typical "cog model" the "height" is 2,5m. In many cases however, the base is shorter than one meter. Angle shots can also be problematic for the analysis. During the data capture the

measuring mark does not move up or down in the direction of the picture, but rather on a diagonal line, which resembles the photo axis when taking the photos. This creates a hurdle for an inexperienced operator.

A stereo picture pair is viewed from two directions. The details of the cog consist of planks and frames, therefore of square timbers. Two, and in most cases, even three of the four edges can be seen in a stereo picture. The fourth edge can never be seen in a single stereo picture. If three edges can be seen the fourth one can be constructed with a CAD-program at a later stage, under the assumption that the timbers have a symmetrical cross section. If only two edges are visible the opposite one can be determined and constructed from the adjacent timbers. The planks are lying on top of the frames. If a frame appears underneath a plank in more than one spot, it can then be assumed that the frame continues regularly underneath the plank. In this way the reverse side of the frame is defined as well. In some cases the invisible edges could also be mapped in neighbouring models. However, most details were only sufficiently well recognizable and perceptible in one stereomodel.

The timbers, rounded by weathering, are an additional problem. This is because the edges of rounded wood cannot be determined from a stereo picture. The edges of these timbers are lying, according to the perspective, always somewhat differently. In this case we mapped a middle axis at the cross section of the wood and in a post-processing phase we constructed an appropriate cylinder along the middle axis.

3.5 Post-processing of the mapped Data

For the post-processing of the data AutoCAD was used. From our experience this program has the widest degree of functionality for the clean-up that was necessary. In this operation, step mapped edges of the same detail from different models were cleaned and gaps in the lines were closed.

Working on the lines turned out to be difficult. The spatial position of the lines in relation to each other can only be understood when the model is swivelled on the screen. Which line fragments belonged to a line that represented a particular edge, could not be determined by the CAD-data only. To clarify details the CAD-screen (AutoCAD) and the stereo screen (PHODIS ST MicroStation) were set up next to each other and the object's development was checked in uncertain cases.

As a further geometrical control we read the approximately 1000 tie points as dot objects with AutoCAD. Since the centre of all of the plastic balls worked as tie points, the mapping could be checked in terms of both errors and plausibility.

4. Prospect

The data that have now been drawn up are raw data. In the coming weeks an inspection of the points and a closing of the gaps in the mapping will follow. In March 2004 a new series of photographs were taken at the site under very good conditions of visibility. These pictures will be used for filling in the still existing gaps in the photogrammetrical model.

5. Applied Software

PhotoModeler, Version 5.0.2, EOS Systems, Vancouver, Canada
BINGO-F, Version 4.0, GIP, Aalen, Germany
PHODIS ST 10, Version 4.2.4, ZI-Imaging, Oberkochen, Germany/USA
MicroStation 95, Bentley Systems, USA
AutoCAD, AutoDesk, USA

The reconstruction of Vrouw Maria: Building a ship from upwards down

The reconstruction work with the Vrouw Maria started in the beginning of 2002 with the making of a model based on the data that had been collected from the time the wreck was found in 1999. The collected data consisted of various digital-, tape- and depth measurements where the quality was sometimes questionable. The idea with the first model was to work out what information was needed and had to be collected in the coming field seasons. During the field season 2002 and 2003 more data was collected and added to the first model. By the end of 2003 there was enough data to start from the beginning by building up the Vrouw Maria step by step using data collected at the wreck site.

The reconstruction of the Vrouw Maria using measures was undertaken in a way, which was opposite compared to that of normal shipbuilding. The hull was more or less constructed from the gunwale downwards. In this article I will briefly summarize how this was done.

From 2D to 3D

The process started with the lining out of the overall length of the ship which was measured from the outside of the stem post to the outside of the sternpost. The stem- and sternposts were then constructed from measurements and rose against the overall length. The correct angles were achieved by measuring the shape of the stem- and sternpost with a goniometer (a digital inclinometer). The third step was to line out the sheer line of the ship that also had been measured with the goniometer. The result of these three steps was a 2-dimensional side view of the ship (Fig 1).

The control points used for the Aqua

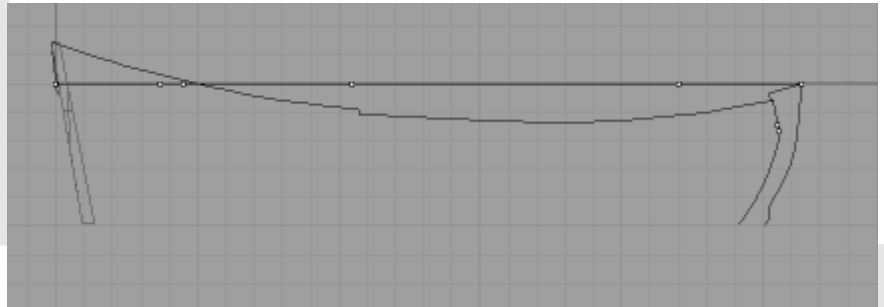

Figure 1.

Metre D100 were then placed out in a 2-dimensional top view with the length of the ship as the centreline. The control points were evenly spread around the wreck on top of the bitts. After the network of control points was laid out it was transferred to the 2-dimensional side view of the ship. This is the first time the model actually turned 3-dimensional, by fitting the two different 2-dimensional views together.

Since the control points, together with the firm constructions in the ship, also served as a base for measuring the width of the ship, the next step was to place out these lines, which once again were made in a 2-dimensional top view. The width was measured from the outside edge of the gunwale at ten places in the ship.

Until this point the work was straight-

forward without any major problems. Getting the right shape of the gunwale from a top view was a bit more difficult. From the aft and all the way to the windlass it was fairly easy to get a smooth hull line with help of the width measurements, but the sharp corner in the bow of the ship was trickier. There was no obvious way to measure the corner so instead scales were placed at the corner and it was then photographed from absolutely dead flat angles. Afterwards dimensional data was extracted from the photographs/video material and the corner constructed from that data (Fig 2).

Shaping the hull

With the contours of the ship's hull and the control points in place it was time to reconstruct the hull shape from the measurements taken with the goniometer. The final thing that was done in the end of the fieldwork

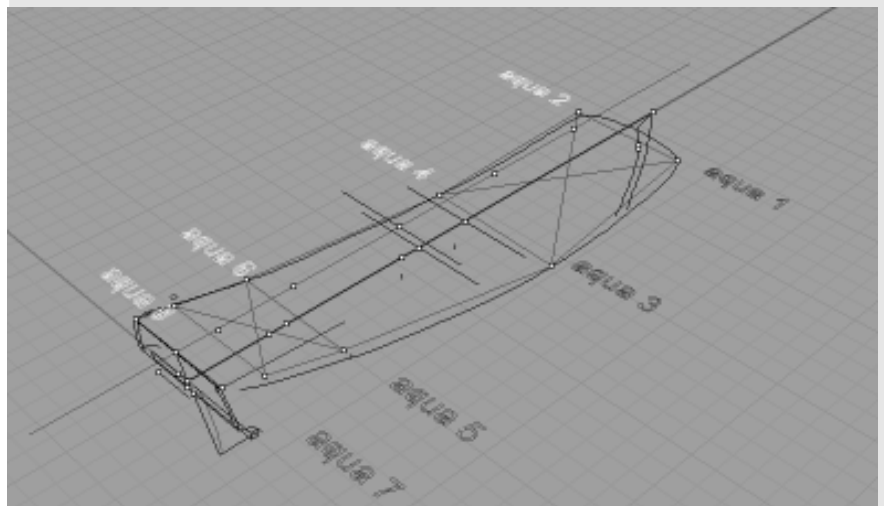

Figure 2.

in 2003 was to join together the different measuring techniques that had been used by way of trilateration measuring. In this way all the cross-sections measured by the goniometer were tied to the control points.

The cross-sections were measured from the gun whale downwards (Wessman 2003, p.14). The only part that caused problems was the stern since the hull radically changed shape in this part. As a result, sections with tighter spacing in-between were needed from the aft part of the ship. After a series of additional sections and control measurements had been taken in 2003 it was possible to finish the aft of the ship.

Before the new sections were added to the model, the transom and the escutcheon were constructed. This was done since these parts played a significant role when the cross sections were measured (Fig. 3).

Filling in details

The deck was fixed to its position by measuring its relation to the sheer line. This was simply done by using a tape measure. At deck level a lot of details were measured with trilate-

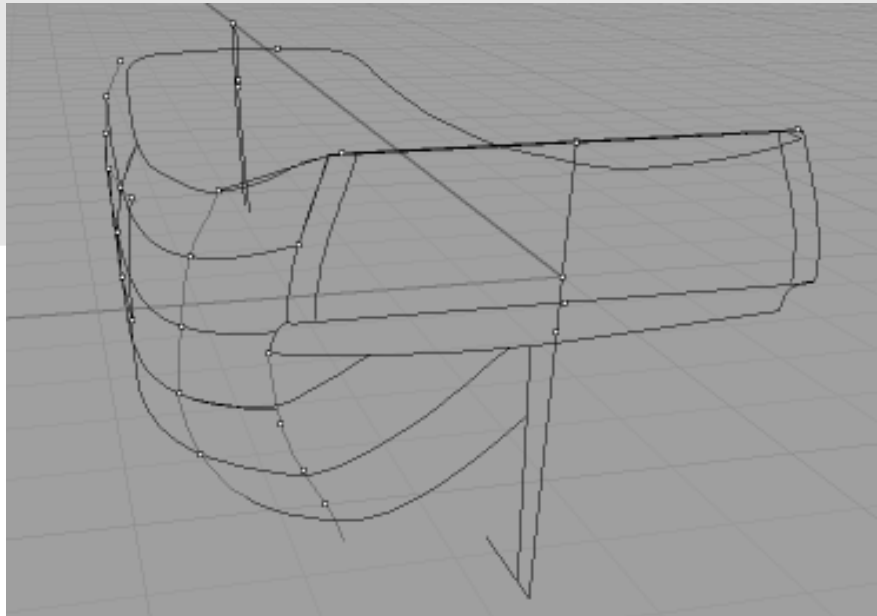

Figure 3.

ration using the control points as a base. This was done for example with the hatches, the windlass and the pumps. In addition, the coach roof beams, the bits (not all of them had a control point) and the masts were also measured, as were the thickness, length, width and circumference of several different construction details in the ship.

All the rig details that are spread a-

round the wreck were measured, but since many of them were on top of each other and/or one end disappeared in the bottom sediment there is a risk of a +/- 5cm mistake in those measurements (Fig. 4).

The amount of detail that can be added is almost endless. The purpose of this work was to get as exact information as possible about the hull, deck and rigging of the ship under these circumstances. The fact that the wreck is resting at a depth of 41m was never used as an excuse. There is still a lot to learn about this ship, the inside still remains mostly a question mark, but many of the other questions have now been solved.

Wessman, Stefan. The documentation and reconstruction of the wreck of Vrouw Maria. MoSS Newsletter 1/2003. A shipwreck research project funded by the European Union Culture 200 programme. p. 14-18.

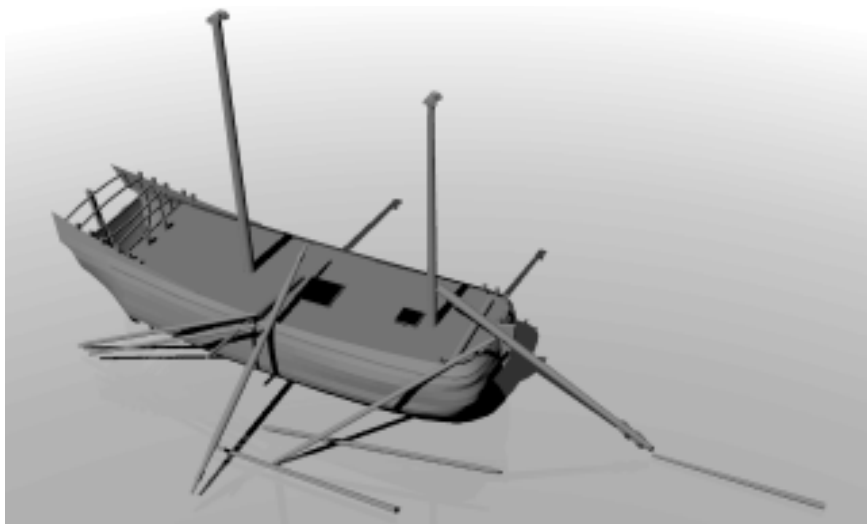

Figure 4.

Safeguarding

Introduction

The degradation of shipwrecks has been investigated by combining Safeguarding with Monitoring and Visualizing. It is the aim of the project to show that the combination of these three themes is essential to the successful management of shipwreck sites in situ. How the Safeguarding theme has been developed within the project can be read about in the different newsletters. The value of combining the three themes is discussed in the article “The Combination of Monitoring, Safeguarding and Visualising” in this volume¹.

Legally safeguarding shipwrecks

The safeguarding of shipwrecks consists of a legal and a physical component, which should be strongly linked. A first inventory of the legal measures that are in use in the different countries of the MoSS project (all are EU-Members) revealed the following points:

There are some (fundamental) differences in the approach to the legal protection of maritime heritage. In the Netherlands (50 years), Finland, Sweden and Denmark (100 years), the protection of shipwrecks is mainly based on the age of a vessel while in Great Britain and Germany (Mecklenburg-Vorpommern) it is based only on the historical and cultural significance of the wreck, regardless of age. In the last two countries it is not decisive whether the wreck is of a certain age, but how much it means in a historical or cultural sense, how valuable it is to the history of society, culture and mankind in the specific country.

The Ancient Monuments Acts used in the different states are usually a so-called “blanket rule” to ensure the

basic protection of (archaeological) heritage. Specific protection is, however, usually provided by using a variety of different rules, regulations and laws, which do not necessarily have to be focussed on a country's cultural heritage, but can be part of its environmental protection, planning-guidance or nature-conservation. Only a few regulations within the EU can yet be seen as being uniform to all countries, such as the environmental assessment regulation, where certain action has to be taken as regards the cultural heritage. The basic attempt to leave cultural affairs as the legal responsibility of each member state is one of the main reasons why states have different legal approaches to the legal safeguarding of wrecks.

In the last decade the approach to archaeological sites has been subject to many fundamental changes, most of which have been beneficial for the common European heritage. Due to the enormous pressure on space i.e. areas being needed for infrastructure, houses and agriculture throughout Europe, the archaeological sites have had to be protected or at least the valuable historical information safeguarded. Under the umbrella of the Council of Europe, a Convention was developed, and since 1992 the Treaty of Valletta (Malta) has been signed by most EU-countries including the six represented in the MoSS-project. However, after twelve years some countries still have to implement this treaty. The Europae Archaeologiae Consilium is undertaking a review on the status of implementation and will inform the Council of European cultural department for their further negotiations.

Another international agreement

appeared in 2001 through UNESCO, when a Convention on the protection of underwater cultural heritage was finalized in Paris after very difficult discussions and negotiations. Although the Convention took four years to be agreed, it has not been signed by the MoSS-Partner-countries, except for Denmark, which has signed but not ratified it (yet). The good news coming out of the Convention is that all the participating UNESCO countries have voted for the Annex of the Convention as a guide to “best practice” for work on underwater archaeological sites.

For the legal safeguarding of wrecks a proper registration of sites is essential. All partner countries have a database. Most of them are general wreck registers or general archaeological sites registers, many of them are also kept in an electronic format.

This first survey of the legal systems in force in the different partner states of the MoSS project showed that there is quite a variation in what is considered to be worth protecting and how these pieces of European common maritime cultural heritage are legally safeguarded. The MoSS-project team focussed especially on the physical methods of preserving maritime resources under water while their legal safeguarding was not taken up beyond this stage of inventory. MoSS however stresses that if we take the “in situ” preservation of our common maritime heritage seriously, it will be necessary to have more universal quality standards concerning the legal protection of maritime heritage among the different EU-member states. The introduction and implementation of international cooperation and agreements concerning protection and management of

¹ M. Manders, Combining “Monitoring, Safeguarding and Visualizing” to Protect our Maritime Heritage, this volume, page 74.

the underwater cultural heritage could be a step in the right direction. It could elevate maritime archaeology to the international level while still respecting national differences and peculiarities.

Physically safeguarding ship wrecks

It is important to understand why shipwrecks are physically safeguarded "in situ".

The first thing that comes to mind and which is one of the basic reasons for "in situ" preservation is that safeguarding is an integral part of the management of our submerged maritime heritage: Objects of maritime historical or archaeological significance that are discovered need to be taken care of to save valuable historic information, that is only available through scientific research on this archive of information. The submerged maritime heritage is extraordinarily preserved due to the water-logged and anaerobic find-conditions that can exist. Most wrecks that are discovered are sticking out of the seabed. If we don't do anything these objects will quickly deteriorate in most cases and vital archaeological information will be lost for ever.

During our investigations the following reasons to safeguard or physically protect a wreck "in situ" were kept in mind. The first two reasons are of a philosophical character while the last three are more pragmatic reasons for

preserving submerged maritime heritage "in situ"²:

1. We have to preserve a representative part of the maritime past for future enjoyment and research.
2. Most countries nowadays have a well-developed legal and regulatory system concerning the protection of maritime archaeological heritage. It means that these countries take responsibility to preserve not only their own, but also a common maritime past. Some international regulations state that the preservation "in situ" should be the first option to consider.³ One way to take care of shipwrecks "in situ" is to physically protect them. This is called the precautionary principle.
3. The number of shipwrecks being discovered is ever increasing and there is not enough capacity to do the research that is necessary for archaeological excavations.
4. The excavation of underwater sites is very expensive. With governments cutting budgets instead of increasing the amount of money available for cultural heritage, this means that only a very small number of discovered wreck sites can be excavated within a short period.
5. Even if a wreck is likely to be excavated, there is usually a long period between the discovery of the object and the actual excavation. Such a site has to be safeguarded in order to guarantee its archaeological value over a longer period.

Safeguarding the MoSS-wreck sites

MoSS has selected four wrecks for research into their successful "in situ"-preservation. Three of them; the Vrouw Maria, the Darsser Cog and the BZN 10 have been investigated with a data logger, woodblocks and soil samples.⁴ At the Eric Nordevall wreck site only a limited visual inspection was carried out into its degradation.⁵

The environments in which these wrecks are lying are very different from each other:

The Eric Nordevall wreck is lying in fresh water and the Vrouw Maria in brackish water with a very low salinity (5 to 7 PSU⁶, average 6, 57 PSU). The Darsser Cog is also lying in brackish water, but with a higher salinity and temporary changes (7 to 23 PSU) while the BZN 10 wreck lies in an environment with a high salinity (12-33 PSU)⁷.

The Eric Nordevall is lying in relatively calm waters with low water movement at a depth of 45 metres. This depth is roughly comparable with that of the Vrouw Maria site. This wreck is lying at 40 metres and although present, the currents around that wreck are usually slow. The wrecks BZN 10 in the Netherlands and the Darsser Cog in Germany however, are subject to far stronger currents. These two wrecks are found in shallow waters. In Germany the depth is around 4

² See the MoSS Newsletter on Safeguarding (Newsletter 2004: III. Theme: The Safeguarding Theme, May 2004) for a more extended article on this issue.

³ UNESCO convention on the protection of underwater cultural heritage of 2001 and the ICOMOS charter on the protection and management of underwater cultural heritage of 1996.

⁴ See the newsletters on the sites, the monitoring newsletter and the chapter on monitoring in this volume.

⁵ See the newsletter about the Eric Nordevall wreck; Newsletter 2003: III. Theme: The Eric Nordevall. October 2003.

⁶ PSU means Practical Salinity Units.

⁷ This information has been derived from the data loggers installed on the Vrouw Maria, BZN 10 and the Darsser Cog. See also the chapter on Monitoring in this volume. No data logger has been installed on the E. Nordevall wreck.

metres while the Dutch site is lying in a tidal zone with strong currents and depth differences of up to 3 metres (6 to 9 metres of depth).

The temperatures at the sites also differ. At the BZN 10 site it ranges from around 2 degrees Celsius in winter (December-January) to 23 degrees Celsius in summer (July-August). At the Darsser Cog site the range is from almost 3 to almost 21 degrees Celsius and at the Vrouw Maria the temperature only differs between 0 to 8 degrees Celsius⁸ with an average of 3,22.

These differences in the natural environment are likely to promote different degrees of deterioration. This is interesting for an EU-project that wants to investigate in a general way how wrecks deteriorate and which measures should be taken to safeguard these sites. Indeed, if we do a simple observational comparison between the four wrecks it is obvious that there are some major differences in the way the wrecks are deteriorating. The Eric Nordevall and the Vrouw Maria are still incredibly intact. This is due to the low (stable) temperatures and low water movements at these sites. The fact that they are lying in relatively deep waters also means that these wrecks cannot be easily visited by sports divers. Although still well preserved, the Darsser Cog and the BZN 10 wreck have fallen apart and are luckily

(partly) buried in the sediment. This has been caused by the strong water movements in these areas and the weakening of the construction elements in the wrecks due to the deterioration of the wood by organisms that are especially active in higher temperatures. Some, like the biggest wood degrader; the ship worm (*Teredo navalis*), also need enough salinity in the water, which is present at the German and the Dutch sites, but not at the Finnish and the Swedish wrecks⁹. The two wrecks in the Netherlands and Germany need reconstruction in order that their original shape can be seen.

Big threats to all four shipwrecks are not only caused by the natural environment and biological deterioration, but also by the human impact from sports diving and the fishing industry. It is a long term process to minimize these influences. This can only be achieved if public opinion is aware of our maritime heritage and if it feels the need to protect it. Enlarging the support for preserving shipwrecks "in situ" is one of the major factors that has been neglected over the years by archaeologists and should be seriously focused upon.

A method of physical protection

The natural degradation of shipwrecks "in situ" can be slowed down or even stopped using all kinds of techniques. In the last few years this has been a subject for investigation in many

countries all over the world. Most of these methods are based on the idea of reburying a site to create an environment with low or even without oxygen. The technique used in the MoSS project is based on this same idea. It has been in use in the Netherlands on different wreck sites in the Wadden Sea for a few years. In the MoSS project however, we monitored the results of this protection, looked at how it worked in different environments and compared the data we gathered with that from the buried (anaerobic) and unburied (aerobic) woodblocks and the data loggers. We have also evaluated the practical use of this system of protection.

The physical protection consists of the covering of a complete wreck site with polypropylene scaffolding or shading net with a density or shading of approximately 50 to 60 %.¹⁰ The sand that is suspended in the water or transported over the seabed by the currents can easily penetrate through the fine mazes. Under the net, the water movement is much lower than outside the net protection. Sand therefore settles and within a short period (the time depends on the natural conditions) an artificial mound is created that covers the whole wreck. It transforms the site from an aerobic into an anaerobic environment.¹¹

This method has many advantages that make it an excellent method to

⁸ This information has been derived from the data loggers on the sites.

⁹ See the chapter on monitoring in this volume.

¹⁰ The size of the holes is related to the kind of sediment, the size of the sediment particles and the transport velocity.

¹¹ See also the MoSS newsletter on the BZN 10 site; Newsletter 2003: IV. Theme: The Burgzand Noord 10. December 2003.

introduce in different countries and environments all over the world. First of all, it is a cheap way to protect even large sites. The material that is used can be bought anywhere. It consists of no more than polypropylene nets, weights and "ty-raps". At the BZN 10 and other Burgzand sites in the Netherlands old anchor chains were used, but sandbags are also effective.¹² The protection is very easy to install and this can even be done by non-archaeological divers. When in place, the protection can be extended and removed easily as well. Of course there are differences in net quality, but in general the materials used are strong and resistant to deterioration under water.

The method is very effective because it uses the environmental conditions to create a mound and therefore becomes part of the environment. If in a particular case there is not enough sediment being transported for quick coverage then the deposition of sand can be easily promoted by using a water dredge. The cover creates an anaerobic environment on the site. It therefore works against many organic degraders that need oxygen, like the ship worm (*Teredo navalis*) and other woodborers, crabs, barnacles, fungi and some species of (aerobic) bacteria.

Because a sloping mound is created, fishing nets do not get entangled in the wreck. It also protects against abrasion caused by currents and reduces the effects of scouring.

One aspect that is important for future research is the fact that objects in

the wreck do not become dispersed over the site.

The mound protects the wreck from being looted; without the proper equipment the site is not easily penetrated.

Due to the little mazes in the net there is still contact between the sand covering the wreck and the environment outside the wreck so the mound can be colonized by (for example) "tube worms" and becomes part of the natural environment.

Some environments are very dynamic but even when the seabed in a very large area changes constantly, this method of protection can still be effective. The net that is covering the wreck is flexible; this means that if the seabed around the wreck deepens out due to (for example) erosion the protection can move along with

it. It will always follow the shape of the seabed.

There are some limitations to the method; if height differences are too big, sand might not be trapped quickly enough and the net will rip. This problem is mainly caused by biological fouling that closes the little mazes in the net. The net has to be placed loosely on the wreck, so it can "wave" in the water catching the sand particles suspended in the water. If there is not enough movement and there is hardly any suspension then this method will not work on its own and using a water dredge might help. Objects and wreck parts sticking out of the seabed can damage the net while it is moving up and down. These obstacles have to be covered.

If the sediment at the site is too coarse the particles might not become suspended and might be too big to penetrate the net. This shows

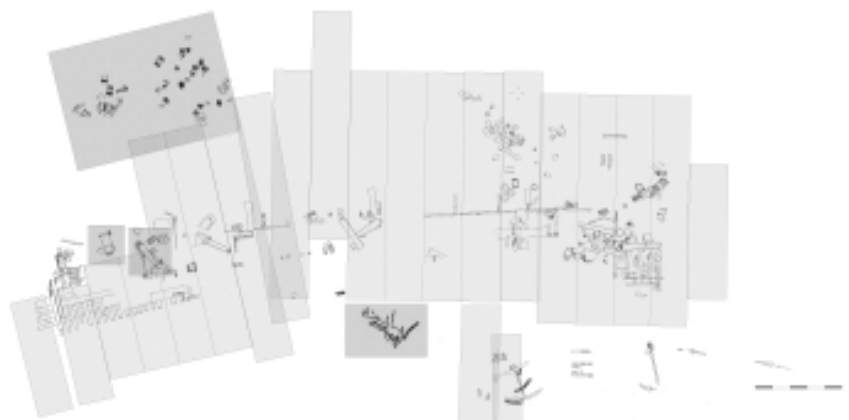

Protection of the BZN 10 site in 2002.

¹² Sandbags were used in Sri Lanka at the Avondster wreck site where this method was also used to test it in a different environment. On this site the protection also proved to be very effective. See for more information about the protection of this site: M. R. Manders, et al., The physical protection of a 17th century VOC shipwreck in Sri Lanka, *Current Science*, Vol.86, No.9, 10 May 2004, 1251-1256. If iron is used to weigh down the nets, it should be placed far outside the wreck site, so as not to influence the environment in and around the wreck.

that it is important to test the protection on the site. Shallow tidal areas with fine sediment are the ideal environments to use this method. Sites with much suspended material in the water caused by currents can be good locations to use the method as well. In these areas however, the nets might move in only one direction and the sedimentation of the site (if not supported by water dredges), will then be much slower.

To conclude; this method can be used in different environments with low costs and for wrecks that need to be preserved for a long period. It can also be used for wrecks or parts of wrecks that need to be protected prior to excavation. The method has its limitations that have to be taken into consideration. It is recommended to test the method out on the site.

Two MoSS-wrecks physically protected: The BZN 10 wreck site
The BZN 10 wreck, an unknown merchant vessel from the 17th century, has been found on the Burgzand, a shallow area in the Wadden Sea that is subject to tidal movements and consists of gullies and old sandbanks.

The main recognized threats to this wreck are biological (the attack on wood by bacteria, fungi, ship worm and other wood borers), geological (abrasion and scouring) and human (fishing and diving).

The wreck has been protected in three stages:

1. Provisional physical protection of



The frames of Darsser Cog above sediment.

small parts of the site that were in immediate danger during the non-intrusive assessment in 2000.

2. Covering the whole site with nets in 2002. The site was limited to the areas where parts of the construction or cargo were protruding above the seabed. This was about 800 square metres.

3. Extension of the site in 2003. A total of 2000 square metres were covered protecting it for a long period and taking into consideration that parts of the wreck have never been uncovered and that the site might be larger than the parts that have been protruding above the seabed. Also, erosion of the seabed in the Burgzand Area was taken into consideration. In the following decades, the seabed will erode at least another two metres¹³.

On the BZN 10 site in the first stage the provisionally protected parts were filled with sediment within a few days. However, the problem was that around these parts the erosion was more severe than anywhere else in the wreck. When the whole wreck was covered the nets were filled within approximately one week and one year later the nets were colonized by tube worms. It also became clear that in the aft of the ship some parts were sticking out too high above the seabed. Sand therefore had to be trapped in several stages in order to be effective. The effect of the protection has been monitored with a Redox-potential sensor. It took no more than 11 days to reach from +36 (aerobic) to -400 mV (anaerobic). This means that the sediment is greatly reducing.¹⁴ By comparing two multi beam sonar recordings of the site (one from April 2002 and one from

¹³ Arent Vos, The Burgzand-Project and MoSS, Newsletter 2003: IV. Theme: The Burgzand Noord 10. December 2003, 4-6.

¹⁴ This information has been derived from the data logger. The data used as an example were taken between the 11th and the 22nd of June 2002. See also the chapter on Monitoring in this Volume.



Protective net covering the wreck of Darss cog.

March 2003) it has been calculated that much more sand has settled on the wreck within this one year period.¹⁵

The Darsser Cog site

The Darsser Cog, an unknown vessel from the early 14th Century, was found in front of the shore of the Region Fishland-Darss (Between Rostock and Rügen) at a depth of approximately 6 metres. The Baltic Sea has a low salinity compared to the North Sea and the Wadden Sea where the BZN 10 was found. This salinity level however seems to be high enough for the *Teredo navalis*. In 2000, while investigating the wreck it became clear that the site was being colonized by this ship worm that has adapted to the brackish conditions of the Baltic Sea since 1993¹⁶. The currents

in this area deposit and remove a lot of sand. Due to this, the Darsser Cog and other wrecks are becoming exposed and getting covered again over time. From the monitoring on the Darsser Cog site, we know that the sediment can be very anaerobic when stable. Thus, the main degraders at this site are biological (*bacteria*, *fungi* and *Teredo navalis*) and geological (abrasion and scouring). There are no diving (except for researchers) and fishing activities on the site, but human impact can be caused by the excavation that has been undertaken.

These conditions made the site favourable to test the protection with polypropylene nets. The wreck was covered in March/April 2004 after a part excavation of the site was finished. Approximately 240 square

metres were covered with 8 nets of 10 metres long and 3 metres wide. The same procedures were used here as on the BZN 10 site. Having learned from the experiences at the BZN 10 site, height differences were flattened out by using the water dredge to deposit sediment and with stones around the ship frames.

Within three days of covering the site it had already become clear that the protection was having a positive effect. Sand was already moving in with the natural currents but sedimentation was also helped along by moving sand under the nets with water dredges. The effect in the long run shall be monitored regularly.

Well preserved shipwreck sites

Although the BZN 10 and the Darsser Cog could be physically protected with nets, therefore prolonging the preservation of valuable archaeological information for at least a few decades, it is obvious that this method is absolutely unusable for well preserved wreck sites like the *Vrouw Maria* and the *Eric Nordevall*. We do however have to keep in mind that although these two ships are still in their original shape they are only as strong as their weakest parts, which could be the iron bolts or the wooden pegs. Eventually they might completely fall apart.

How can these wrecks be physically protected? This will be a great challenge over the coming years. Whatever kind of method is developed, we will always have to ask ourselves the questions; what do we protect it

¹⁵ This research has been executed by the ROB in co-operation with RWS Noord-Holland and IJsselmeer. See also Seger van der Brenk, Innovative research at the BZN 10 wreck site, Newsletter 2003: IV. Theme: The Burgzand Noord 10. December 2003, 19-21.

¹⁶ Since a penetration of salt water from the North Sea in 1993 *Teredo navalis* has been spreading out in the Western part of the Baltic. The ship worm today has already reached the west coast of the Island of Rügen. See also the MoSS Newsletter about the Darsser Cog: Newsletter 2003: II. Theme: The Darss Cog. June 2003.

for and from, for how long do we want to preserve it and against what costs?

Small base to evaluate

MoSS realizes that the testing of only one method of physical protection is a narrow base on which to evaluate preservation “in situ”. However, the project team decided to follow this line of investigation due to the time limits and the fact that MoSS aims to show ways of carrying out research and not to make final statements on this topic.

In many countries preservation “in situ” is starting to become a key issue and a subject for intense research. Many new methods are being developed and evaluated. MoSS compares the data from safeguarding with that of monitoring and visualizing. It shows that the method of using scaffolding nets can be very effective. Taking the practical advantages of the method into account, it is a good method to use in many other areas of the world with fine sediment transportation. The team stresses, however, that this method will not be the only one suitable for the preservation of underwater archaeological sites. The effectiveness of the protection with polypropylene nets also relies a great deal on a few factors in the natural environment such as the sedimentation rate and the characteristics of the seabed.

Public awareness

Although it is necessary to have legal and physical ways to protect maritime heritage underwater, maybe the most important and easily forgotten



Creating awareness to amateur divers.

way to create a basis for the protection of these objects from our past is to get public support for the cause.

If we create public awareness, where the responsibility for our maritime heritage is felt by a large group of people, it will form a basis again for political support. There are many ways to create public awareness. It forms the link between the Safeguarding of wrecks and their Visualizing¹⁷.

A Universal Management Plan

One way to create public awareness is to make maritime archaeology and the enormous archive of shipwrecks in European waters more accessible and transparent for others.

A method to do not only this, but to also make it possible to compare

sites from different countries with each other is the management plan that has been developed within the project. If this plan comes to be used in more countries, then we will finally be able to manage our common maritime heritage together on a larger scale. Almost by definition, the maritime past is not that of one isolated country, but the past and history of many of us. In this regard, boundaries and borders are not very well defined. The safeguarding of one wreck is then the responsibility of many countries. By making uniform management plans for different shipwrecks in Europe an international under water “archive” will be established showing the immense variety and value of our common maritime heritage. The information that will be gathered can be used for predictive

¹⁷ See the visualizing article in this volume, page 49.

modelling as well.

The management plan is designed as follows: It has an administrative part, which can be used by all sorts of people, such as users of the area, policy makers and law enforcement groups. The second part is filled with archaeological information about the site and an assessment based on this information. The third part is a cultural evaluation, about its historical or cultural importance. Can this wreck be used as an example of a certain time or ship type or is it maybe the best of its kind? Is the object suitable for exhibition? The last part is the actual management of the site. What has been done, what will be done and against what costs?

The management plan has been designed in such a way that it can be started with a minimum of information and built up over the years.¹⁸

Conclusion

The safeguarding of shipwrecks is the essential issue in the preservation of shipwrecks "in situ". It provides the tools to protect wrecks that are considered to be of archaeological,

cultural or historical significance. The countries within the MoSS project all have extensive laws and regulatory systems to protect wrecks. There is no uniformity in legal safeguarding within the EU. MoSS however stresses that if we take the preservation "in situ" of our common maritime heritage seriously, it will be necessary to have more universal quality standards concerning the legal protection of maritime heritage among the different EU-member states. The introduction and implementation of international regulations concerning protection and management of the underwater cultural heritage could be a step in the right direction.

Physical safeguarding has been the main focus of the project. One system that is thought to be easily used in many different areas in the world has been tested. This method, covering a wreck with polypropylene nets has proved to be very effective in the Wadden Sea, the southern Baltic Sea and even in Galle Harbour (Sri Lanka). This system of physical safeguarding has not only been visually monitored, but the effect has also been investigated with data

loggers and by comparing wood samples. MoSS realizes that this method will not solve all the problems arising in connection with the degradation of shipwrecks and their protection "in situ". It also realises that there will be more effective systems developed. It was the aim of the project to show ways to protect shipwrecks "in situ" and to open the way for further research and debate. MoSS also stresses that creating public awareness is an essential method to protect shipwrecks that are usually not visible for the general public.

The management plan that has been developed is a way to present the enormous archive of valuable archaeological data on the seabed. When introduced in other countries with a maritime heritage it would make the comparison of shipwrecks from different areas in the world far easier. The store of archaeological information would become accessible for many scholars and scientists as well as the policy-makers who have to make decisions that could influence the protection of our common maritime heritage.

¹⁸ More information about the management plan can be found in Newsletter 2004: III. Theme: The Safeguarding Theme. May 2004 and the four Management plans (from the Eric Nordevall, Vrouw Maria, Darsser Cog and the BZN 10).

The structure of the management plan:

Management plan of shipwreck site [name]

0. Administrative details

- 0.1 Date
- 0.2 Client
- 0.3 Executed by (contractor)
- 0.4 Approved authorities
- 0.5 Central registration number
- 0.6 Location research area
- 0.7 Co-ordinates
- 0.8 Environmental context
 - Coastal Geology
 - Climate
 - Flora and Fauna
 - Human impact
- 0.9 Size of research area
- 0.10 Depth
- 0.11 Owner terrain
- 0.12 Reported by
- 0.13 Periods of research
- 0.14 Site definition
- 0.15 Deposition of archives
- 0.16 Legal status
- 0.17 Recognized threats
- 0.18 Date of re-assessment / re-evaluation

1. Introduction

- 1.1 Previous studies
- 1.2 Historical context

2. Assessment of the site

- 2.1 Description of research assignment
 - 2.1.1 Reference to working standards
 - 2.1.2 Research objectives
 - 2.1.3 Expected results
 - 2.1.4 Aims/ wishes of the purchaser
 - 2.1.5 Imposed research conditions
 - 2.1.6 Evaluations in-between
- 2.2 Working procedure
 - 2.2.1 Research methods
 - 2.2.2 Imposed work conditions
 - 2.2.3 Modus operandi
 - 2.2.4 Natural sciences, applied sciences and other research
- 2.3 Research results
 - 2.3.1 Environmental research
 - 2.3.2 Physical condition

- 2.3.2.1 Finds visible on surface
- 2.3.2.2 Completeness (how much does it resemble the original state, quantity)
 - 2.3.2.2.1 Completeness wreck parts
 - 2.3.2.2.2 Stratigraphy intact
 - 2.3.2.2.3 Mobilia in situ
 - 2.3.2.2.4 Relation between mobilia and wreck parts
 - 2.3.2.2.5 Relation between mobilia
 - 2.3.2.2.6 Stability natural environment

2.3.3 State of preservation

- 2.3.3.1 Organic wreck parts
- 2.3.3.2 Metal wreck parts
- 2.3.3.3 Organic mobilia
- 2.3.3.4 Metal mobilia

2.3.4 Cultural-historic and archaeological data

- 2.3.4.1 Identification
 - 2.3.4.1.1 Cultural context
 - 2.3.4.1.2 Century
 - 2.3.4.1.3 Exact dating
 - 2.3.4.1.4 Function
 - 2.3.4.1.5 Type
 - 2.3.4.1.6 Operating area
 - 2.3.4.1.7 Propulsion
 - 2.3.4.1.8 Size
 - 2.3.4.1.9 Material
 - 2.3.4.1.10 Building tradition
 - 2.3.4.1.11 Inventory
 - 2.3.4.1.12 Cargo
 - 2.3.4.1.13 Personal belongings
- 2.3.4.2 Constructional features

2.4 Risk assessment

- 2.4.1 Natural impact
- 2.4.2 Human impact

3. Cultural valuation of shipwreck [name]

3.1 Experience aspects (quality)

- 3.1.1 Aesthetic values
 - 3.1.1.1 Visible
 - 3.1.1.1.1 Visible as landscape element
 - 3.1.1.1.2 Visible as exposition element
- 3.1.2 Memory value
 - 3.1.2.1 Historic

3.2 Physical quality

- 3.2.1 Structural integrity
 - 3.2.1.1 Presence of ship construction
 - 3.2.1.2 Completeness of the wreck parts
 - 3.2.1.3 Stratigraphic conditions
 - 3.2.1.4 Mobilia (portable antiquities) in situ
 - 3.2.1.4.1 Relation between mobilia and ship parts
 - 3.2.1.4.2 Relation between mobilia
 - 3.2.1.5 Stability of the natural environment

3.2.2 State of preservation

3.2.2.1 Wreck parts

3.2.2.1.1 Organic material

3.2.2.1.2 Metal

3.2.2.1.3 Composite

3.2.2.2 Artefacts

3.2.2.2.1 Organic material

3.2.2.2.2 An-organic

3.2.2.2.3 Composite

3.3 Quality of archaeological information

3.3.1 Representative value

3.3.1.1 Chronological

3.3.1.2 Regional

3.3.2 Significance of information

3.3.2.1 Geographical significance

3.3.2.2 Historical or archaeological significance

3.4 Conclusion

4. Site management

4.1 Cost-benefit analysis and general conclusion

4.2 Site management agenda

4.2.1 Safeguarding

4.2.1.1 Legal

4.2.1.2 Physical

4.2.2 Monitoring

[actions planned]

4.2.3 Visualizing

[actions planned]

4.2.4 Finance

4.3 Date of re-assessments/re-evaluation Attachments (examples)

Attachments (examples)

1. Shortlist NAVIS

2. Maps of research area

3. Maps of location artefacts

4. Overview drawing

5. Cross sections

6. Pictures

7. Other

8. Catalogue/ find list

Etc.

Combining “Monitoring, Safeguarding and Visualizing” to Protect our Maritime Heritage

The MoSS project consists of the three research aspects Monitoring, Safeguarding and Visualizing. Why have we chosen this approach? What is the surplus value in combining these three aspects?

The whole project is designed to find effective ways to protect our common maritime heritage under water. This is not only the interest of maritime archaeologists, but also of a much broader general public. Our heritage is only protected well if this has widespread public support. This public should consist of scholars, decision makers and the people who consider these shipwrecks as part of their own history. For them it has to be made clear what can still be found under water, how these finds can be used to reconstruct our past, why wrecks are deteriorating, how these processes can be stopped or slowed down and at what cost. In other words: the shipwrecks on the seabed and the threats to them have to be investigated and visualized to create understanding and arouse interest.

If we want to protect a site, we have to know what is threatening it. This means; to watch and record what is happening over a longer period in order to know what can be damaging for ship wrecks. By systematically observing wrecks (monitoring) we will understand more about degradation processes. If we are able to take away a few major factors that degrade wood for example, it is obvious that this degradation will slow down. Safeguarding therefore depends to a great extent on the information gained from monitoring wrecks. After safeguarding a wreck it is also important that on-site monitoring continues to keep track of the development of the site

and the effectiveness of the protective measures (see also the Newsletter on Monitoring and the Safeguarding Newsletter).

The visualisation of wreck sites can mean a lot of things. Visualisation is an important part of the method to document and investigate a site. Wrecks under water are usually not easily accessible. Research on these sites is concentrated in a very short period. The visualisation of the excavation, monitoring and safeguarding enables scientists to do research even when they are not physically present on the site. Since archaeological research on a site can take years to complete, a visual documentation is essential to keep track of everything that has been done. Visualisation also enables us to open up an archive of archaeologically interesting shipwrecks to a wider audience. There are many ways to do this. The *Vrouw Maria* wreck and the *Eric Nordevall* are so well preserved that, although more has been done, the conventional ways of documenting the site by photographing and video registration are enough to interest a large public audience and to emphasise the importance of these wrecks for reconstructing our past. The *Darsser Cog* site is the oldest of the investigated wrecks. It needs a little bit more work to make the wreck accessible for a wider audience. Therefore it has been documented and visualized by photographic mapping. The *BZN 10* wreck is also well preserved from an archaeologist's point of view. At least half of the ship is still protected in the sediment. The fact that it has been broken up means that the remains have to be reconstructed by the scientists and “translated” to the public (See also the Newsletter on Visualisation).

Not long ago there was only one kind of visual monitoring. This meant that the only information about the condition of a shipwreck were the written accounts of what the researchers had seen. It is still important to register these visual changes, but now there are many more methods to quantitatively measure the condition of a wreck. These methods, like the use of a data logger to measure the environmental conditions, are potentially more objective and can be more easily compared. It is however very important that data about the deterioration of shipwrecks are accessible and understandable for more people than just the researchers working on the site. It is therefore important to visualize these numbers into, for example, graphics.

The safeguarding of shipwrecks is a long term process. This doesn't stop after physical protection. Over the years, the situation in and around a wreck site can change. A protection measure can be ineffective after many years as well. For example: If there is heavy erosion on a site, the wreck can be physically protected by being covered up. This has been done with polypropylene nets at the *BZN-10* and other sites in the Wadden Sea as well as at the *Darsser Cog* site. This method is very effective (see also the newsletter of the *BZN 10*-site). However, the erosion in the vicinity of the site goes on. After many years, the seabed around the protected wreck can be eroded so much that sand starts to flow away from under the protective nets. Regular monitoring can identify this threat at an early stage and other measures can be taken.

It is usually not only the archaeologist's call to take protective measures; they have to be approved

by policy-makers as well. These policy-makers are influenced by other (electoral) groups in society. It is therefore also important to illustrate the degrading effects on shipwrecks, what kind of wrecks there are and why we should protect them. This is an important task within the Visualizing Theme that should create more understanding and support for the “in situ” preservation of maritime heritage.

In conclusion: The themes within the MoSS project (Monitoring, Safeguarding and Visualizing) have separately been proved to be important for the protection of maritime heritage. However, combining them within one project and for the management of different shipwrecks showed how crucial a multi-disciplinary approach is: Monitoring helps to select the right measures to safeguard a site. Safeguarding a site is a long term process. This process has to be monitored to ensure that measures taken are still valid after many years. The monitoring can also provide new information that can change the measures taken to protect the site.

Raw data gained from the monitoring can be made visual for a wider public; other scientists, policy-makers and the general public. It is important for them to know why and how wrecks are threatened, what kind of measures have been taken to protect maritime heritage and against what cost.

Consideration: The information gathered from shipwrecks has to be presented as objectively as possible. This is not easy. What, for example, is a well preserved wreck? Does it have to resemble its original appearance as a ship, like the Vrouw Maria or the Eric Nordevall? Maybe a wreck can also be considered as being well preserved when it is possible to

reconstruct it in its original shape, like the BZN10 wreck and the Darsser Cog? This can be discussed within an archaeological framework, but what if other people join this discussion? For some of them a well preserved wreck might be one that consists of well preserved wood. But what is well preserved wood? A biologist might qualify this as wood that still has its original physical qualities like strength or chemical elements while an archaeologist is merely interested in its outer appearance: can I still investigate the shape and the use of the piece of wood and are woodworking marks still present?

In future the protection of maritime heritage will benefit from scholars of different disciplines speaking the same language and using the same terminology. The MoSS project was too short to come up with a glossary that gives definitions to maritime archaeological terms. However, the Management plan that was developed might be introduced in many different countries that would benefit greatly from it.

Project evaluation

Six nations have participated in the MoSS project: Denmark, Finland, Germany, The Netherlands, Sweden and the United Kingdom. Of these, Denmark has participated as an associate partner. This has included consultation in the development of the research programme and monitoring theme and contributing to the interpretation and writing up of the results. The following text is based on the written evaluations sent in by the six partners of the project. The head of each participating country's research group has written the respective texts. The present author/editor has taken the points raised in the different evaluation texts and structured them under the following headings: Project management; Cooperation within the project; Organization; Scientific aspects; Aspects on the project themes of Safeguarding, Monitoring and Visualization; Future developments.

The evaluations of the representatives of the six MoSS nations given under the different headings have been ordered in alphabetic order according to the name of respective nation.

Management

The following views have been presented by the partners on the issue of the management of the project:

The National Museum, Denmark:

The application for funds was made before the research strategy had been finalized or determined. This made it extremely difficult to devise a cohesive research programme, which included the chosen wreck sites, and to tailor it to the money available. The coordination and management of the monitoring theme was a key element

in the project. It was therefore frustrating when decisions were made and registered at various meetings, which were then not followed up. Many problems that were encountered could have been solved much earlier in the project had there been more commitment / participation / cooperation and adherence by members to the monitoring theme. The project's scope was too ambitious for the time scale and funds available, which has involved extra expenditure for many of the partners.

The Section of Maritime Archaeology, The National Board of Antiquities, Finland:

From the coordinator's point of view, the administration of the project and the finding of suitable ways to work in practice have been the most challenging and sometimes also, the most difficult parts of the project. Even though all the participants are European countries, there are distinctions between them in terms of their working culture. The administration has been very time consuming and there have been a lot of new things to learn as regards managing this kind of project. As the coordinator Finland has had the responsibility for the budget and for reporting to the commission. This has required good organization and lots of skilful staff working full time on the project. For example, the time calculated for the coordinator was 50 % of normal office hours. This has not been enough. For such a big project it is recommended that there should be a full-time working staff.

From our perspective we can say that the administration has developed during the three years, and that certain routines in the managing of the budget and reporting have emerged. Communication within the project has mostly been done by

email. Email is an effective and fast way to communicate, but it is also very important to arrange meetings and use telephone. The amount of emails sent within the project has been very big, and sometimes the important messages are not noticed as quickly as they should.

It would also have been very useful to the project, if the communication between the European Commission and the project leader had been more interactive. In a pilot project like the MoSS project it is not very easy to adjust the reporting and accounting of the European Commission to the coordinators' national administrative system, and we would have needed more information to do this effectively. The project would have benefited from an information assistant, who could have taken care of the communications between the partners, distributing information to the media and to other co-operative parties, and updating our Internet-site.

In this kind of project there is a great possibility to be very creative and to test new methods. There are many important aspects and tasks inherent in the themes of the MoSS project. However, in such a short time span as the three years allotted the project, achieving full results while completing all the tasks agreed on in the project agreement has taken more time and effort than was originally envisaged. The first year of the project was spent in establishing contacts with each other and in finding ways to work together constructively. That is why many of the tasks scheduled to be undertaken the first year were not undertaken. The other even more important reason for this was that the funding from the European Commission did not come until the end of 2001. Therefore, the project did not

have the necessary resources to undertake the planned scientific research or for the printing of publications when the project officially began.

The experience gained from the research done within the monitoring and safeguarding themes and also from the management policies in our partners' countries have provided much valuable knowledge about the managing of underwater cultural heritage. We find the Management plan of shipwreck sites, created in the MoSS project, to be very good and also useful. In Finland we are going to use it on other sites besides the *Vrouw Maria*.

This was the first time Finland planned, coordinated and participated in an international project like the MoSS project, though we have undertaken co-operative work before, especially with the Nordic countries. The MoSS project was designed as a pilot project in maritime archaeology on both a national and an international level. There have been mistakes and miscalculations, but in general the project can be evaluated as a good starting point for future positive co-operation between European maritime archaeologists. We have collected and used a lot of new knowledge, which we could not have obtained in such a short time without the MoSS project and such intensive cooperation. In our seminars we have been able to widen the network to maritime archaeologists from overseas and also Russia, and that experience has been very valuable.

The NISA, The Netherlands:

The MoSS project has provided opportunities to work together on a wider scale than is usual. Maritime archaeology is by definition an international profession. However,

usually research is done by and only in the country where an object has been found. Now maritime archaeology has been taken beyond this point. The people involved in the project from the various countries may now understand more about how maritime heritage is taken care of in the other countries; what the problems and advantages are. We can learn from this. Solutions that have been discovered and which are working well within the six project countries will probably be shown to be good solutions when applied also in other countries. Things are now tested in a wider context. We think that the project partners now understand much more than before, that the maritime heritage of one nation can also be of significant importance for other countries and that co-operation in preserving or investigating it is a good option.

MoSS, we think, was a good pilot project in the sense that it looked at the bigger picture. The conclusions should also be on that level. It will form a good basis for further work. MoSS was not only about how to find out about the degradation of shipwrecks, but especially about how maritime heritage is being and should be taken care of in different countries. It was also about how we can help each other in this. MoSS does offer various tools to continue this work to make the world a better place for archaeologically valuable shipwrecks and for maritime archaeology.

Södertörns högskola (University college), Sweden:

The MoSS project has taken up and treated general, maritime archaeological development issues in a comprehensive and qualified way. The accounting and evaluative tasks have been performed in a well-coordinated and professional way by

the coordinator.

The Mary Rose Archaeological Services Ltd (MRAS), United Kingdom:

The development of the research design was not agreed at the start of the project and the project has been too short in duration to give a statistically significant data collection. The data logger technology was unreliable and untested and the original budget was too inflexible so as not to allow for changes to working methodology.

The project has for the British partner led to useful collaboration with Portsmouth University, which is also working on the Bacpoles project with the NISA. MRAS is primarily a commercial archaeological contractor unlike our partners who are all nationally or federally funded research organizations.

Cooperation within the project

On the issue of cooperation within the project the partners have presented the following views:

The National Museum, Denmark:

It has been beneficial meeting researchers from other European institutions and discussing experiences within the field of research. It has also been valuable to build networks from the various seminars held and to receive ideas for the continuation of collaboration between the various institutions involved in this project and other members of the European Union.

The Section of Maritime Archaeology, The National Board of Antiquities, Finland:

Co-operation at an international level has been developed in Finland during the MoSS-project. Working with the partners and their institutions in the

project has been fruitful and we have learned a lot. In the seminars there have been many international guests (who are) working in the maritime field. Meeting these professionals and exchanging information and experiences with them has been very valuable.

The ROB/NISA, The Netherlands:
It has been very interesting talking to, learning from and holding discussions with colleagues from other countries that have different backgrounds and opinions. Still we were working for the same goals. Specifically in the Netherlands, we have had opportunities to work together with specialists from the NIOZ (Netherlands Institute for the Research of the Sea) and the RWS (Ministry of Transport, public works and water management).

Södertörns högskola (University college), Sweden:
It has been interesting and gratifying to cooperate on mutual issues with five other nations in the northern part of Europe. Some practical communication problems did arise in the beginning, but it was possible to overcome them. It has also been a creative and constructive task as the project editor to coordinate and bring about the information and results of the project in a printed form.

The Mary Rose Archaeological Services Ltd (MRAS), United Kingdom:
The benefits have been meeting European colleagues and discussing and sharing our mutual knowledge and experience. It has also been meaningful to learn about the different national legal structures in place to protect the submerged archaeological landscapes and historic shipwreck sites. An opportunity was also given to see the facilities available to the MOSS partners to

enable them to provide a national/regional maritime conservation and archaeological service.

Organization

The following views have been presented by the partners on the issue of the organization of the project:

The Section of Maritime Archaeology, The National Board of Antiquities, Finland:

The Maritime Museum of Finland has been responsible for the co-ordination and management of the MoSS-project. The lack of permanent staff (only one maritime archaeologist working permanently) has been a difficulty and there are now two researchers and a project secretary hired for the MoSS-project. Only the researchers are working full time with the EU-project. This has caused some problems: a project as big as MoSS should have required full time employees, because its time schedule was very tight and there were a lot of tasks in the project. The changes in the organization of the National Board of Antiquities during the project also meant extra work and complicated the work in the MoSS-project to a certain degree. The biggest single problem however, was caused by the fact that almost everyone from the group of people that originally designed the project has been absent from the project for a long time or left the project at some point for various reasons. This causes always difficulties and delays because of the employing and training new staff to be substitutes of the absent persons. We have gained a lot of advantages from the project, but also noticed that it has been difficult to take care of all the daily routines in our everyday work and undertake project tasks at the same time.

One of the national tasks in the MoSS project was to get more experience for the young maritime archaeologists in Finland. In connection with this, during the three years of the MoSS project the staff has gained much experience from the new perspectives about doing scientific research being used at the Vrouw Maria wreck as well as about the management of our underwater heritage. This project has been a valuable experience also at the organizational level.

The NISA, The Netherlands:
EU projects have proved to be very bureaucratic. There is a lot of paperwork to be done and that takes up much time. It is clear that the way they are structured is designed for cultural and not scientific projects. It was stated that we could not claim salaries within MoSS. This meant that the bureaucratic things had to be done with few people, which resulted in some of the research time being lost. Further, almost by definition, it is impossible to plan a research project well for a period as long as 4 years. There have to be moments of evaluation in it, when you can also shift the budget. Some ideas prove to be wrong and others need more time to be solved. If, however, time and money is structured and planned in the beginning it is difficult to change this within the project and this slows down the scientific work: you have to stick by the original plan. We would have liked to see something different: For example, it would have been more effective if the project group made the plan and after one year there was an evaluation where considerable amounts of the budget could have been reallocated.

We should have had more time to structure the project in the beginning so that we didn't have to improvise that much during the project and so

that we could have made good agreements with other partners (with for example, EauxSys Ltd, the company who made the data loggers).

Within the Netherlands, it was a pity that this project was not fully embraced by the ROB and that things had to be solved on the margin of other work that had to be done. We managed, but it placed considerable pressure on the people that were involved. Now at the end of the project this is slowly being recognised. In the Netherlands, we are taking care of maritime heritage in a responsible way. This is why we could deliver a lot of input in this project. Now we can also take it up to a wider European level. The Texel roads are an example of how international maritime history is. There are German, Swedish, French, Russian and English wrecks, which are located there, and being investigated. There are ships that were trading with the East Indies, the West Indies, and The Baltic Sea countries, Norway, England, France, The Iberian Peninsula and the Mediterranean. These wrecks are in Dutch waters, but are they all Dutch maritime heritage? Yes, but many of them are shared with other countries and maybe we should say that especially seagoing ships are of common heritage; some more important to one country than others. We have been glad to be involved in the MoSS project and we would like to thank all the partners for the work that has been done and for the fun that has been had. Archaeology can be fun as well.

Scientific aspects

The partners concerning the scientific aspects of the project have forwarded the following assessments:

The National Museum, Denmark:

One of the benefits of the project has been that it has provided access to the experience of oceanographers that work with water quality parameters on a daily basis. It has also given us the possibility to learn more about the infrastructure of European research funding.

The Section of Maritime Archaeology, The National Board of Antiquities, Finland:

Thanks to the MoSS-project the wreck of the Vrouw Maria is now the best safeguarded and monitored wreck in Finland. It is also the first Finnish wreck with a decent management plan. When it comes to its documentation, the Vrouw Maria is probably one of the best in situ documented wrecks in the world. Working with the different themes of the project at the Vrouw Maria has given us experience of the different methods and equipment that can come into play/ be employed during archaeological investigations.

The Archaeological State Museum of Mecklenburg-Vorpommern, Germany:

Profiting from the research done in the MoSS Project, the German project wreck, the Darss Cog, is now one of the most detailed in situ investigated and safeguarded medieval wrecks in the coastal waters of the Baltic Sea.

The NISA, The Netherlands:

It has not always been easy to understand different scientific cultures and the way things are approached in maritime archaeology. Within the MoSS project it has been possible to establish ways to widen the understanding of these mechanisms. The different scientific cultures represented in the project gave us

also some understanding of how maritime heritage is taken care of in different nations: there is not a good or a bad way as regards this issue, there are instead several alternatives.

The communication in the beginning of the project was not optimal, but it was understandable as the working procedure and methods were just beginning to form at this stage of the project. This proves the importance of arranging meetings for the partners in a project like this one. Within the MoSS project we have done this at least three times a year and that must be seen as a minimum.

Aspects on the Monitoring theme

The following views have been presented by the partners on the issue of the monitoring theme within the project:

The National Museum, Denmark:

A benefit of the project has been to develop the use of data loggers for monitoring water quality parameters over a range of different archaeological under water sites.

The Section of Maritime Archaeology, The National Board of Antiquities, Finland:

At this stage of the project, before we have got the results from the analyses, it is not possible to make a proper evaluation of the benefits of the wood samples and the analyses done in project. So far we just have preliminary results. Nevertheless, we now have scientific proof that we do not have threats like Teredo Navalis or other woodborers at the Vrouw Maria-site.

The data logger that has been placed at the site has worked well and due to this fact we now have results of the physical and chemical conditions

at the site that cover a two-year period. The co-operation with our national research institutions like the Marine Research Institute (on the data logger-data) and the University of Helsinki has improved and become more effective during the MoSS project, which has benefited the research done on the monitoring theme. Within the project we have learned methods to survey the environmental conditions at wreck sites.

The monitoring research done (for example, the locating and monitoring of the condition of wood samples on the sea bed) at the Vrouw Maria site has proven to be problematic because of the depth, lack of daylight and the consistence of the sediment layers at the site (the moraine layer above the bottom clay layer is very hard). The monitoring system was created without taking the specific conditions at each site into consideration. We think that it is very important, that people, who know the conditions at the site, should participate in the planning of the monitoring research.

The Archaeological State Museum of Mecklenburg-Vorpommern, Germany:

The project has for the first time given the possibility to investigate systematically the biological threats to the under water cultural heritage in the Southern Baltic Sea area. The result of this has been that it has become evident that the threats to wooden wrecks created by fungi, bacteria and in the first instance by *Teredo navalis*, are much more relevant than had been thought earlier.

The project has also provided a new strategy for monitoring in the waters of the Baltic Sea. The investigations have shown that after only a short time, the infestation of wrecks by biological organisms is possible.

These investigations, started in and by the MoSS project, should be done at different areas in the Baltic to get a clear analysis of the threats that currently exist at the sites. As a result it should hopefully be possible to get new information about the existing or even non-existing special habitats of woodborers, specialized fungi and bacteria.

The use of data loggers at the Darss-Cog site has shown that there is no specific microclimate at the site. Following on from this it will also be possible in the future to use already available data from the monitoring systems of the environmental departments and research-institutions. A lot of additional costs can be saved in this way.

The ROB/NISA, The Netherlands:

The most interesting aspect has been the combination between monitoring, safeguarding and visualizing. The monitoring has given us a lot of new information on the degradation of shipwrecks under water. The monitoring with data loggers on the site in combination with the woodblocks provided us new inside information about how a wreck degrades in an anaerobic and aerobic environment. Specifically, for the Netherlands, it has been very interesting to test degrading factors under the physical protection that has been invented in the Netherlands and to see if it is an effective method.

Södertörns högskola (University college), Sweden:

The project has not integrated the Swedish wreck, of the paddle wheeler E. Nordevall, in the monitoring program, developed within the project. This has been applied to the other three wrecks in the project. This can be seen as negative thing as it would have been valuable to have the

experiences provided by the systematic monitoring of the environmental conditions of the site in question and its influence on the ship structure. The E. Nordevall is situated in fresh water and because of this it would have been useful to have data from this site. Fresh water sites are quite common in the Baltic Sea area and this would have allowed us to compare the data from this site with the ones from the other sites in the project, which are in brackish and salt water respectively.

The Mary Rose Archaeological Services Ltd (MRAS), United Kingdom:

The project has given us the opportunity to share monitoring technology with our North European partners and to compare the environmental variables in the Baltic Sea off Finland and Germany with the Wadden Sea, Netherlands with the objective of eventually being able to predict the impact of environmental variables on historic ship-wreck sites. It has also given us the opportunity to develop data logger technology and to incorporate a range of new monitoring techniques and to evaluate their performance in different maritime locations.

Aspects on the Safeguarding theme

The following views have been presented by the partners on the issue of the safeguarding theme within the project:

The National Museum, Denmark:

The development within the project of a general management plan for wreck sites, which actually takes into consideration the effects of the environment on the future preservation of the wreck site, is of value for the development of maritime archaeology.

The Section of Maritime Archaeology, The National Board of Antiquities, Finland:

The Vrouw Maria has a safety area around her and a surveillance camera is pointed at the site 24 hours in a day. We can easily say that there is no immediate danger for this specific wreck, but there is a great audience that is aware of the monetary value of this underwater cultural heritage and there are hundreds of wrecks without the same kind of protection as the Vrouw Maria has. It has been a difficult task to show the public that the value of the wrecks is in the information they hold about our past. It is important to point out that we should not act hastily with these kinds of unique archaeological sites. For this work we now have several tools from the MoSS project. The management plan for the Vrouw Maria has set guidelines for the new plans for other different, but also important sites.

The Archaeological State Museum of Mecklenburg-Vorpommern, Germany:

The results of the project within the monitoring theme lead to the challenge of developing new strategies in safeguarding. The idea of leaving the wrecks in situ as proposed in the Unesco Convention will for example, only be possible, when special techniques are developed and used that avoid or minimize the biological threats.

The Dutch method of covering a wreck was tested for the first time in the Baltic Sea within the MoSS project and the initial results are positive. The most destructive biological threats (fungi and *Teredo navalis*) can be avoided in this way. The system is not too expensive and can be developed into a routine to safeguard wooden wrecks. Amateurs can also

be asked to install and control the system, so that it will not necessarily involve high costs in a long-term perspective.

The authorities in the MoSS-countries will hopefully undertake the development of a master management plan for shipwreck sites. It might be anticipated that this would lead to a common European standard in the management of under water cultural heritage.

The ROB/NISA, The Netherlands:

It has been very interesting to test the covering system that has been developed in the Netherlands in the MoSS-project. In combination with the monitoring, its effectiveness against degrading organisms and abrasion has been tested. The system has also successfully been used in Mecklenburg-Vorpommern at the Darsser Cog site.

The management plan has also been very useful. It proved that a system like this could be used all over Europe.

Södertörns högskola (University college), Sweden:

The project has taken up important issues on the safeguarding and preservation of shipwrecks for discussion and practical application, which will be of value for the care of submerged cultural resources. To this belong the methods applied for the preservation of partly broken down wrecks by covering them up, which have been used on the Dutch and German wrecks in the project.

It has also been interesting to work with and put together the management plan for the Swedish wreck in the project, with the aim of introducing this concept for the safeguarding of shipwrecks in Sweden more generally.

Methods for the safeguarding and

preservation of well-preserved shipwrecks, which stand more or less intact on the bottom, remain to be developed. This type of wreck is not uncommon in the project area and is often given a high safeguarding value. It is therefore important to develop safeguarding techniques for them. This issue is not yet solved and has to be further discussed and developed, which has been highlighted within the project.

The Mary Rose Archaeological Services Ltd (MRAS), United Kingdom:

It has been valuable to learn about the technique, used in the Netherlands for the net covering of wreck sites to trap and bury submerged structures by trapping water borne sediments. We were also impressed by the NISA technique for assessing the importance of wreck sites and the management plans for safeguarding wreck sites.

Aspects on the Visualization theme

The following views have been presented by the partners on the issue of the visualization theme within the project:

The National Museum, Denmark:

It has been of value to learn about other fields of archaeological research occurring within the project such as the visualizing of shipwrecks.

The Section of Maritime Archaeology, The National Board of Antiquities, Finland:

The hull of the Vrouw Maria is almost intact which gives a lot of opportunities as regards its visualization. Careful documentation of the site has helped us to find better ways to visualize the wreck and the original ship as it was in the end of the 18th

century. Visualization has been an ongoing process where sketches and artist's views have been continually redrawn during the past three years based on new evidence gathered from the wreck during the documentation process. By the end of the MoSS-project we were able to show the Vrouw Maria to the public in video clips, photographs, drawings, animations and as a 3D model and a model of the wreck.

The Archaeological State Museum of Mecklenburg-Vorpommern, Germany:

In the MoSS Project it has been possible to develop a routine for the photogrammetrical documentation of wreck sites. This allows a timesaving photographic documentation to be undertaken at the site under water, while the exact measuring and drawing up of the details can be done later in the office. This means that very expensive ship-times and manpower can be reduced, so that it will be possible in the future to survey more wrecks during one field-campaign and as a result, to produce more and more precise data than it had been possible to do previously. During the MoSS project, we became aware of the visualising techniques, strategies and methods of the other MoSS-partners, which will be valuable for the future activities of our museum in this field.

During the MoSS-Seminar about "Visualising" in 2003 we received new information from external experts about how to establish, manage and promote under water cultural heritage in an underwater-park. This information has already been very valuable for the designing and developing of a project for an underwater park in Germany. These ideas have led to a project application (the Rutilus-Project) for the Interreg IIIb-program-

me that was submitted in February 2004.

The dissemination of information by the MoSS Project, especially the homepage, the folders and the newsletters, have lead to the fact, that today the Darss-Cog is one of the best known archaeological sites in north-western Germany. The fact, that nearly all the ship's remains are still preserved in situ shows, that it is possible to gather a lot of relevant information about a wreck-site in a non-destructive way and without lifting the wreck.

Södertörns högskola (University college), Sweden:

The project has taken the initiative to comprehensively cover questions concerning the visualisation of shipwrecks in various conditions and in different ways:

The visualization of shipwrecks on their sites for divers under water; The visualization for a general, non-diving audience above water through different kinds of recording and visualization technique; The visualization in connection with diving tourism and the development of marine archaeological parks on the sites of old shipwrecks; The questions concerning the under water visualization techniques of the future, seen in relation to the development of under water technology and the transference of pictures from the under water landscape to the society above the water.

The Mary Rose Archaeological Services Ltd (MRAS), United Kingdom:

We have been interested to learn from the German partner about the development of underwater photogrammetry; from the German and Swedish partners about the construction of 1/1 working replicas of

historic ships and from the German and Dutch partners about the practical applications of model making.

Future developments

The following comments were provided by the partners on the issue of the future development of the subjects and themes taken up by the MoSS project:

The Archaeological State Museum of Mecklenburg-Vorpommern, Germany:

The results of the MoSS project will be the starting point of a new phase for the safeguarding and management of shipwreck-sites in the waters of Mecklenburg-Vorpommern. The master management plan that was developed shall be used as a routine for the management of wrecks in our waters. Using its structure we are also going to develop a master management plan for archaeological sites and monuments on land.

The results of the MoSS project lead to the challenge of more intensively monitoring shipwreck sites in German waters. In the future our museum will try to gather all the available, relevant information from other national and international institutions and try to set up a monitoring-network to investigate the environmental conditions, especially the biological threats, to under water sites.

The fruitful exchange of knowledge and best practice that occurred in the MoSS project shall be continued and expanded in different ways: conferences, research projects, management projects, publications, exchange of staff, etc.

The Section of Maritime Archaeology, The National Board of Antiquities, Finland:

The MoSS-project has been of a big value to the Finnish maritime archaeo-

logy despite of the problems we have had. Development and good practices within the MoSS-project can be applied to other sites than Vrouw Maria also and we are now planning to use the MoSS master manage plan to our important wreck sites. It is a very good tool for the management and protection of the sites.

Because of the visualization of the Vrouw Maria it is now probably the best known wreck in Finland and it is also known abroad, specially in the Netherlands. Distributing information of the Vrouw Maria and the MoSS-project has helped our task to make people in Finland more aware of the underwater cultural heritage, which was one of our main goals.

Besides the development in Finland in the maritime field that will continue, the continuation of the international co-operation would also will be an important task.

The ROB/NISA, The Netherlands:

MoSS has been a pilot project, where much has been learned. It should have a follow up, but one that has been thought through well and that is based upon the experiences of this project. The partners in the MoSS project have found each other and will continue to communicate and exchange information.

what is MoSS?

The MoSS project is based on four shipwrecks, all of which are of great significance from a European point of view and show a diversity of intercultural relationships throughout a long period of history. The wrecks are located in Netherlands, Germany, Sweden, and Finland, and they represent different vessel types. The oldest of the wrecks is dated to the 13th century whereas the youngest is from the middle of the 19th century. The wrecks are in different kinds of underwater environments; in sea, lake, and brackish waters, and the conditions on the sites are both stable and unstable. The wrecks have preserved extremely well; two of them are almost intact.

The MoSS project has three main themes: monitoring, safeguarding and visualizing shipwrecks. The first theme includes monitoring the condition of the wrecks, or in other words doing research on the degradation of shipwrecks under water.

The aim of this theme is to develop and improve the methods used in monitoring the physical and environmental conditions of shipwrecks. The second theme is safeguarding, which aims at outlining and developing models to protect shipwrecks so that also the needs of different public groups are taken into account. The third theme is visualizing. The four shipwreck sites will be made physically visible using underwater and other images. The project will be advertised multilingually to the European public.

The MoSS project consists of field-work, Internet site, publications, posters, leaflets, reports, articles, meetings, and seminars. One of the objectives is to produce information not only to the general public but also to the experts in the area of protecting the cultural heritage. The aim is to awaken European peoples' interest to our common underwater cultural heritage and to have the general public participate in protecting the heritage. The wrecks of the project – ships that sailed on European waters – act as examples of maritime history as they tell us about the many local and international dimensions of the European culture.

The MoSS project is organized by The Maritime Museum of Finland (co-ordinator), The Mary Rose Archaeological Services Ltd. (United Kingdom), The National Service for Archaeological Heritage: Netherlands Institute for Ship- and Underwater Archaeology ROB/NISA (the Netherlands), The National Museum of Denmark/Centre for Maritime Archaeology (Denmark), The Department for Preservation of Archaeological Sites and Monuments / Archaeological State Museum of Mecklenburg-Vorpommern (Germany), and Södertörns högskola – University College (Sweden).

The MoSS Project is the first international shipwreck project that European Community Culture 2000 Programme funds. The European Community Culture 2000 Programme is a programme that supports international cultural co-operation projects that involve organizers from several countries. The objectives are among other things to encourage co-operation, to promote the common European cultural heritage, and to disseminate the knowledge of the history and culture of the peoples of Europe. In 2001, it was the first time projects on sub-aquatic archaeology were especially called to take part in the program.

Publisher:
The National Board of Antiquities
PL 913, FIN-00101
Helsinki, Finland

Editor: Carl Olof Cederlund
Phone +46 8 608 4201
carl-olof.cederlund@sh.se

Language checking:
Andrew Stickley, MA
Phone +46 8 608 4148
andrew.stickley@sh.se

Layout: Vesa Hautsalo
Phone +358 9 4050 9072
vesa.hautsalo@nba.fi

Gummerus Printing
Saarijärvi, Finland 2004

MoSS